

part 3

Survey of Approaches and Attitudes

It has been said that the best method of presentation is to tell the audience what you are going to say; say it; and then tell the audience what you have said. The first two parts of this injunction have been fulfilled, and only the last part remains to be carried out. We have chosen to conclude this volume with Armer's review, "Attitudes toward Intelligent Machines," and Minsky's review, "Steps toward Artificial Intelligence." We would be presumptuous if we were to review at length these two excellent pieces, and so we shall ask the reader to pause for only two short introductory paragraphs.

Attitudes toward intelligent behavior by computers have been influenced by lack of knowledge and understanding of the work which has taken place and by preconceived notions of what constitutes proof of intelligence. This volume has provided the reader with reports of the current state of the art in research on machine intelligence. Armer provides a review and analysis of preconceived notions concerning machine intelligence. His report is based on a survey of the literature and on his own observations in the United States and the USSR. Although Armer himself has been associated with much of the work reported in this volume, he presents an appealing middle-of-the-road position on the question, "Can computers think?"

The final article in this volume is Minsky's thoughtful review of the trials, errors, and successes of artificial intelligence research. Minsky attempts to supply the field with structure and to state the problems that remain to be solved. This is a unique and important re-

port and is required reading for a thorough understanding of the field.

Paul Armer is head of the Computer Sciences Department of the RAND Corporation.

Marvin Minsky is Associate Professor of Electrical Engineering at Massachusetts Institute of Technology.

ATTITUDES TOWARD INTELLIGENT MACHINES

by Paul Armer

"A BIRD IS AN INSTRUMENT WORKING ACCORDING TO MATHEMATICAL LAW, WHICH INSTRUMENT IT IS WITHIN THE CAPACITY OF MAN TO REPRODUCE WITH ALL ITS MOVEMENTS."

Leonardo da Vinci (1452-1519)

This is an attempt to analyze attitudes and arguments brought forth by questions like "Can machines think?" and "Can machines exhibit intelligence?" Its purpose is to improve the climate which surrounds research in the field of machine or artificial intelligence. Its goal is not to convince those who answer the above questions negatively that they are wrong (although an attempt will be made to refute some of the negative arguments) but that they should be tolerant of research investigating these questions. The negative attitudes existent today tend to inhibit such research (MacGowan, 1960).¹

History

Before examining the current arguments and attitudes toward artificial intelligence, let us look at some of the history of this discussion, for these questions have been around for a long time.

Samuel Butler (1835-1902), in *Erewhon and Erewhon Revisited* (1933), concocted a civil war between the "machinists" and the "anti-machinists." (Victory, incidentally, went to the "anti-machinists.") Butler stated "there is no security against the ultimate development of mechanical consciousness in the fact of machines possessing little consciousness now" and speculated that the time might come when "man shall become to the

¹ Almost an entire book, *Computers and Common Sense, The Myth of Thinking Machines*, has been devoted to condemning artificial intelligence research (Taube, 1961). Readers who have been exposed to this book should refer to reviews of it by Richard Laing (1962) and Walter R. Reitman (1962), particularly the former.

machines what the horse and dog are to us." Discussion of this topic apparently took place in Babbage's time (1792-1871), for the Countess of Lovelace commented on it, negatively, in her writings on Babbage's efforts (Bowden, 1953). The topic came into prominence in the late 1940's when Babbage's dreams became a reality with the completion of the first large digital computers. When the popular press applied the term "giant brains" to these machines, computer builders and users, myself included, immediately arose to the defense of the human intellect. We hastened to proclaim that computers did not "think"; they only did arithmetic quite rapidly.

A. M. Turing, who earlier had written one of the most important papers in the computer field on the universality of machines (1936, 1937), published in 1950 a paper entitled, "Computing Machinery and Intelligence." In it he circumvented the problem of properly defining the words "machine" and "thinking" and examined instead the question of a game wherein an interrogator, who can communicate with a human and a machine via teletype, but does not know which is which, is to decide which is the machine. This is now known throughout the computer field as "Turing's Test."

Discussion of machine intelligence died down (but not out) in the early and mid-1950's but has come back in the last several years stronger than ever before. In fact, it has recently invaded the pages of *Science* (MacGowan, 1960; Wiener, 1960; Taube, 1960; Samuel, 1960b).

A Way of Thinking about Thinking

Before beginning an examination of the negative arguments, allow me to introduce a concept which will aid in discussing these arguments and which may help resolve some of the semantic difficulties associated with discussions of "Can machines think?" Like Turing, I avoid defining "to think." Instead, observe that thinking is a continuum, an n -dimensional continuum. This notion is certainly not new, for it has existed since man first compared his mental abilities with another man's, and it is implicit in all of the positive arguments on machine intelligence. Psychologists long ago developed "intelligence quotient" as a yardstick in this continuum, and their concept of "factors" is indicative of the n -dimensionality of the continuum of intelligence. The use of the one-dimensional "I.Q." is obviously an oversimplification of reality. Although the concept of an n -dimensional continuum for intelligence is not new, and although it is implicit in many discussions of artificial intelligence, it is rarely stated explicitly.

An analogy may be drawn with the continuum of the ability to transport. With respect to speed in transporting people from New York to Los Angeles, the jet airplane of today outshines all other existing trans-

portation vehicles. But it does not compare favorably, costwise, with ships for transporting newsprint from British Columbia to California. Existing commercial jet transports cannot transport people from one lake to another. A Cadillac may be the most comfortable vehicle to transport people short distances over a good network of roads, but it is hardly a substitute for the jeep in the environment of ground warfare—the jeep's forte is versatility and flexibility. In this dimension, in the continuum of the ability to transport, man outshines the jeep, for man can go where jeeps cannot, just as the jeep can go where Cadillacs cannot. But men cannot carry the load that a jeep can nor can men move with the speed of the jeep.

Similarly, comparisons can be made between men and machines in the continuum of thinking. If there is objection to the use of the word "thinking," then "ability to process information" or some similar term can be used. But it must be admitted that there exists some continuum of behavior in which men and machines coexist and in which they can be compared. (See Fig. 1.)

An n -dimensional continuum is difficult to draw when n is large, so let's examine a two-dimensional one, realizing that reality is far from being that simple. With respect to raw speed, machines outdo men, but when it comes to the sophistication of the information processes available, machines look pretty poor. This dimension deserves further discussion. While the repertoire of today's machines is quite simple—a few basic arithmetic operations and comparisons—man's information processes are very complex. Let me illustrate this point with the following incident. We have all had the experience of trying to recall the name of a person we have once met. On a particular occasion Dr. Willis Ware and I were both trying to recall an individual's name. We recounted to one another his physical characteristics, where he worked, what he did, etc. But his name eluded us. After some time, I turned to Dr. Ware and said, "His name begins with a 'Z'." At which point he snapped his fingers and correctly said, "That's it, it's Frizell!"

Now, of course, the basic question is "Can the machines' capabilities in this dimension be improved?" Let me turn the question around—Is there any evidence that they cannot? I know of none. In fact, over the last decade I think impressive progress has been made. It's easy to underestimate the advances, for "intelligence" is a slippery concept. As Marvin Minsky put it, "You regard an action as intelligent until you understand it. In explaining, you explain away" (1959a).

Today's computers, even with their

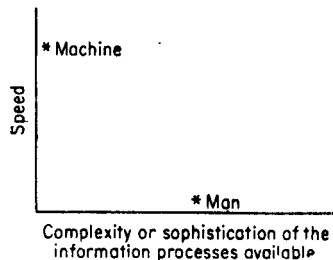

Figure 1

limited capability in the sophistication dimension, have had tremendous impact on science and technology. Accomplishments of the last decade in the fields of nuclear energy, missiles and space would have been impossible without computers. If we can push the capabilities of computers² further out in the sophistication dimension, won't they have an even greater impact? *In this context then, the goal of research on artificial intelligence can be stated—it is simply an attempt to push machine behavior further out into this continuum.*

It is irrelevant whether or not there may exist some upper bound above which machines cannot go in this continuum. Even if such a boundary exists, there is no evidence that it is located close to the position occupied by today's machines. Is it not possible that we might one day understand the logical processes which went on in Dr. Ware's head and then mechanize them on a machine? We obviously will not achieve such a goal unless someone believes that it is possible and tries to do it. One does not have to believe that the boundary is nonexistent in order to try; one need only believe that the boundary is much further out than the position occupied by today's machines.

Intelligent Machines and Today's Digital Computer

A common attitude toward today's computers is that such machines are strictly arithmetic devices. While it is true that machines were first built to carry out repetitive arithmetic operations, they are capable of other, nonnumeric tasks. The essence of the computer is the manipulation of symbols—it is only a historical accident that the first application involved numeric symbols. This incorrect notion of the computer as a strictly numeric device results in the inability of many to conceive of the computer as a device exhibiting intelligent behavior, since this would require that the process be reduced to a numerical one. The reaction of many people to statements about intelligent behavior by machines seems to indicate that they take such statements to imply complete functional equivalence between the machine and the human brain. Since this complete functional equivalence does not exist, such people believe they have thereby debunked intelligent machines. Their argument is hollow since this equivalence was never implied. Intelligent behavior on the part of a machine no more implies complete functional equivalence between machine and brain than flying by an airplane implies complete functional equivalence between plane and bird.

The concept of comparing the behavior of men and machines in an n -dimensional continuum recognizes differences as well as similarities.

²I make no distinction here between the attributes of the computer and those of the program which controls the computer.

For example, a common argument against machine intelligence is that the brain is a living thing—the machine is not. In our continuum we simply recognize the dimension of living and note that machines and men occupy different positions in this dimension.

While I do believe that today's digital computers can exhibit intelligent behavior, I do not hold that the intelligent machines of the 1970's will necessarily resemble today's machines, either functionally or physically. In particular, in my desire to see machines pushed further out in the continuum of intelligence, my interests in the dimension of speed are very minor; the organizational aspects (sophistication of the information processes) are obviously much more important. Likewise, I hold no brief for the strictly digital approach; a combination of analog and digital equipment may prove to be better. I do not mean to disown the digital computer, for it will be a most important tool in the endeavor to advance in our continuum.

Some of the Negative Arguments

1. The Argument of Invidious Comparison

Considering the behavior of men and machines in the context of intelligence being a multidimensional continuum, an argument that a machine cannot play chess because "it could only operate on standard-size pieces and could not recognize as chessmen the innumerable pieces of different design which the human player recognizes and moves around quite simply" (Taube, 1960) is like saying that the Wright brothers' airplane could not fly because it could not fly nonstop from Los Angeles to New York nor could it land in a tree like a bird. Why must the test of intelligence be that the machine achieve identically the same point in the continuum as man? Is the test of flying the achievement of the same point in the continuum of flying as that reached by a bird?

2. The Argument of Superexcellence

Many of the negativists³ seem to say that the only evidence of machine intelligence they will accept is an achievement in our continuum seldom achieved by man. For example, they belittle efforts at musical composition by machine because the present output compares miserably with that of Mozart or Chopin. How many *men* can produce music that compares favorably? The ultimate argument of this kind occurred at a recent meeting in England, during which a discussant stated that he would not accept the fact that machines could think until one proved the famous

³ The terms "negativists" and "positivists" are used in this report to classify those who do not and those who do, respectively, believe machines can exhibit intelligent behavior. Of course, variations of degree exist.

conjecture of Fermat, better known as Fermat's last theorem. By this logic one concludes that, to this date, no man has been capable of thinking, since the conjecture remains unproven.

3. The Argument by Definition

There are many variations of this type of argument. For example, some negativists want to include in their definition of intelligent behavior the requirement that it be carried out by a living organism. With such a definition, machines do not behave intelligently. However, there does still exist machine behavior which can be compared with human behavior. To conclude that research on the simulation of such human behavior with a machine is wrong, as some have done, because the machine is not living, is like concluding that research on the simulation of the functions of the human heart with an artificial heart is wrong because the artificial organ is not a living one.

4. The Argument by Stipulation

An examination of the arguments advanced by the negativists reveals that many of them are not arguments at all, but only statements. They dismiss the notion out of hand, saying things like, "Let's settle this once and for all, machines cannot think!" or "A computer is not a giant brain, in spite of what some of the Sunday supplements and science fiction writers would have you believe. It is a remarkably fast and phenomenally accurate moron" (Andree, 1958).

5. The Argument by False Attribution

Typical of this type of argument is the following:

The Manchester machine which was set to solve chess problems presumably proceeded by this method, namely by reviewing all the possible consequences of all possible moves. This, incidentally, reveals all the strength and weakness of the mechanism. It can review far more numerous possibilities in a given time than can a human being, but it has to review all possibilities. The human player can view the board as a whole and intuitively reject a number of possibilities. The machine cannot do either of these (Hugh-Jones, 1956).

The statements about machine behavior in the above quotation are simply not true. While it is true that some of the early approaches to chess-playing machines were in the nature of attempts to review *all* possibilities in limited depth (Kister *et al.*, 1957), this is not the only way in which the problem can be approached. The chess-playing routine of Newell, Shaw, and Simon (1958*b*) does *not* examine all possibilities. And those which it does consider it examines in varying detail. The routine rejects

moves which appear to be worthless; it selects moves which appear to be good ones and examines them in depth to ascertain that they are indeed good. An earlier routine developed by this same team to prove theorems in logic (Newell, Shaw and Simon, 1957a) did not examine all possible proofs—to do so with today's computers would literally take endless time. Rather, the routine searched through the maze of possible proofs for ones which looked promising and investigated them. It relied on knowing which approaches had worked before. Most of those who scoff about research on artificial intelligence turn out to be unaware of the details of what is going on in such research today; it is little wonder that they frequently make erroneous statements about the field.

6. The Argument by False Extrapolation

This class of argument is typified by extrapolations based on assumptions that machine properties are invariant. For example:

The human memory is a filing system that has a far greater capacity than that of the largest thinking machine built. A mechanical brain that had as many tubes or relays as the human brain has nerve cells (some ten billion) would not fit into the Empire State Building, and would require the entire output of Niagara Falls to supply the power and the Niagara River to cool it. Moreover, such a computer could operate but a fraction of a second at a time before several thousand of its tubes would fail and have to be replaced (Troll, 1954).

The point is tied to the vacuum tube (the article was written in 1954) and has therefore already been weakened by the appearance of the transistor, which requires less space and power and is considerably more reliable than the vacuum tube. An offsetting development is that the estimate of the number of nerve cells is undoubtedly too low. However, on the horizon are construction techniques involving the use of evaporated films, where the details of the machine will not be visible under an optical microscope (Shoulders, 1960). It seems reasonable to expect that it will be possible with these techniques to house in one cubic foot of space the same number of logical elements as exist in the human brain. Power requirements will be trivial.

7. The Obedient Slave Argument

One often hears statements like "The machine can only do what it is told to do." People who advance this obedient slave argument would seem to be thinking that they are countering others who have pointed to a large conglomeration of unconnected transistors, resistors and electronic components, and said "It thinks." Certainly man is involved in machine intelli-

gence—so are parents and teachers in human intelligence. Do we deny flying to an airplane because a man is piloting it or even to an unmanned flight because a man designed it?

The negativists who say “the machine can only do what it is told to do” overlook the fact that they have not qualified their statement as to what is the limit of what the machine can be told to do. What evidence exists concerning the location of that limit? Might it not become possible to tell a machine to learn to do a given task, a task usually considered to require intelligence? Many of the tasks being accomplished with computers today were not considered possible ten years ago.

Recent Computer Tasks and Milestones

The mounting list of tasks which can now be carried out on a computer but which we normally consider requiring intelligence when performed by humans, includes such things as:

Proving theorems in logic and plane geometry (Newell, Shaw and Simon, 1957*a*; Gelernter, 1960*a*)

Playing checkers and chess (Samuel, 1959; Newell, Shaw and Simon, 1958*b*)

Assembly line balancing (Tonge, 1961*a*)

Composing music (Hiller and Isaacson, 1959)

Designing motors (Goodwin, 1958)

Recognition of manual Morse code (Gold, 1959)

Solving calculus problems (Slagle, 1961)

The collection of capabilities which have been ascribed solely to humans in the past is being slowly chipped away by the application of computers. Space precludes going further into the evidence for machine intelligence; this topic is well covered in the articles previously cited and in other papers (Newell, Shaw and Simon, 1956; Milligan, 1959; Minsky, 1961*a*). Such evidence is, of course, the basis for many of the arguments advanced by the positivists.

To prove that machines *today* do *not* exhibit intelligence, it is only necessary to define a lower bound in our continuum which is above the behavior exhibited by the machines and then say that behavior above that bound is intelligent and below it is not intelligent. This is a variant of the proof by definition. Many who use this gambit have been redefining the lower bound so that it is continually above what machines can do today. For example, we find

Perhaps the most flexible concept is that any mental process which can be adequately reproduced by automatic systems is not thinking (Meszar, 1953).

This redefinition may not be done consciously. A skill which seems highly intelligent in others becomes much less impressive to us when we acquire that skill ourselves. It would be useful to have at hand some milestones for the future. Turing's test is one such milestone (1950) but additional ones are needed. To this end a clearly defined task is required which is, at present, in the exclusive domain of humans (and therefore incontestably "thinking") but which may eventually yield to accomplishment by machines.

Rivalry Between Man and Machines

There is a strong personal factor in the attitude of many negativists. I'm sure it was a major factor in my being a negativist ten years ago. To concede that machines can exhibit intelligence is to admit that man has a rival in an area previously held to be within the sole province of man. To illustrate this point, let me quote from a letter received at RAND:

. . . semantics may have a lot to do with the degree of enthusiasm for supporting research in this area (artificial intelligence). Subjectively, the terms "intelligent machine" or "thinking machine" disturb me and even seem a bit threatening: I am a human being, and therefore "intelligent" and these inhuman devices are going to compete with me and may even beat me out. On the other hand, if the very same black boxes were labelled "problem solver," or even "adaptive problem solver," they would seem much more friendly, capable of helping me in the most effective way to do things that I want to do better, but, best of all, I'd still be the boss. This observation is wholly subjective and emotional. . . .

Another explanation of why some negativists feel the way they do is related to what might be called the "sins of the positivists." Exaggerated claims of accomplishments, particularly from the publicity departments of computer manufacturers, have resulted in such a strong reaction within the scientific community that many swing too far in the opposite direction.

Da Vinci and Flying

At this point allow me to paraphrase the quotation of da Vinci's, with which this paper was begun, and also, with the benefit of hindsight, expand on it somewhat. Thus, he might have said:

When men understood the natural laws which govern the flight of a bird, man will be able to build a flying machine.

While it is true that man wasted a good deal of time and effort trying to build a flying machine that flapped its wings like a bird, the important point is that it was the understanding of the law of aerodynamic lift (even though the understanding was quite imperfect at first) over an airfoil which enabled men to build flying machines. A bird isn't sustained in the air by the hand of God—natural laws govern its flight. Similarly, natural laws govern what went on in Dr. Ware's head when he produced "Frizell" from my erroneous but related clue. Thus, I see no reason why we won't be able to duplicate in hardware the very powerful processes of association which the human brain has, once we understand them. And if man gained an understanding of the processes of aerodynamics, may he not also obtain an understanding of the information processes of the human brain?

There are other facets to this analogy with flight; it, too, is a continuum, and some once thought that the speed of sound represented a boundary beyond which flight was impossible.

Approaches to the Problem of Building an Intelligent Machine

This topic can perhaps be expounded best with another analogy. Suppose we are given a device which we know exhibits intelligent behavior because we have observed it in action. We would like to build a machine which approaches it in capability (or better yet, exceeds it). We bring in a group of men to study the basic components of the device to understand how they work. These men apply pulses to subsets of the leads, and observe what each component does; they try to understand why the device behaves as it does in terms of basic physics and chemistry. They also seek to learn how these components function in subassemblies.

A second group of men approach the problem from the point of view that the device is a "black box" which they are not able to open. This group observes that some of the appendages of the device are obviously input devices while others are output devices. They observe the device in operation and attempt to theorize how it works. They proceed on the basis that it will not be necessary that the machine they are to construct have the same basic components as exist in the device under study. They believe that if they can understand the logical operation of the existing device, they can duplicate its logic in their own machine, using components they understand and can make.

This second group makes conjectures about the logical construction of the device and tries these conjectures out on a computer which they have at hand. These theories are very crude at first and do not mirror the behavior of the "black box" very well, but over time the resemblance improves.

Because we learned a lesson from the effort spent on attempting to

build a flying machine that flapped its wings, we set a third group to work studying "intelligence and information processing" *per se* and building up a science in the area.

There is much common ground among the three groups and they keep each other posted on results to date. Furthermore, they all use computers to aid them in their research. The groups combine their know-how along the way to build better computers (low-I.Q. intelligent machines) on which to try out their conjectures. Eventually, the three groups "come together in the middle" and build a machine which is almost as capable as our model. They then turn to the task of building an even better one.

In the real-life situation of studying the human brain, the first group, studying components and assemblies thereof, is represented by physiological work. The second, or "black-box" group, is represented by psychological efforts to explain human mental activity. This analogy represents, I believe, a plausible scenario for the way things might go in trying to understand the human mind.

Russian Attitudes

Our examination thus far has been Western in origin; in view of the impact that achievement of the goals of research on artificial intelligence would have on the technological posture of the United States vis-à-vis the Soviet Union, it might be interesting to look at Soviet attitudes toward intelligent machines. As one might suspect, Soviet attitudes have been quite similar to Western ones. Positivists and negativists exist, and each camp advances the same sort of arguments as their Western counterparts. For example, there are negativists who advance the obedient slave argument. Academician S. A. Lebedev, head of the Institute of Precise Mechanics and Computational Techniques and host to the U.S. Exchange Delegation in Computers which visited the USSR in the last two weeks of May, 1959 (of which I was a member), on two occasions dismissed my questions concerning his attitude toward intelligent machines with the statement "Machines can do no more than they are instructed to do."

Their literature is filled with discussions of comparisons between men and machines. In 1961, an entire book, *Philosophical Problems of Cybernetics* (1961), was published on this topic. It was obvious from the questions asked of our delegation by the Russians about Western attitudes that it is a hotly debated issue. In the USSR, research on artificial intelligence is a part of cybernetics, the term coined by Wiener (1948) and now a household word in the Soviet Union. Cybernetics is also used as an umbrella term for research in automatic control, automation, computers, programming, information retrieval, language translation, etc. It is universally recognized as an area related to both men and machines, and the

requirement for an interdisciplinary (engineering, mathematics, computing, biology, psychology, physiology, physics, chemistry, linguistics, etc.) approach to such research is also recognized.

As in the West, the use of the term "giant brains" in the late 1940's resulted in a massive revulsion among the Soviet scientific community, and universal rush to the defense of the human mind. The degree of the revulsion was such that several Soviet writers have blamed it for the fact that Russia presently lags the U.S. in the digital-computer field (Shaginyan, 1959). One finds frequent references in the Russian literature to the existence of a negative attitude toward cybernetics, and to the persistence of this attitude for a period of about ten years.

Soviet literature on cybernetics frequently gives credit to Wiener, von Neumann, and other Westerners for pioneering the field. It also contains many references to the work of Pavlov and mixes in much political discussion of communism vs. capitalism, and even of Marx and Lenin. For example, we have:

Karl Marx was the first to make use implicitly and anticipatingly of cybernetical ways of thought, or to express it more pointedly, Karl Marx was the first cybernetician! . . . (Klaus, 1960).

There are some strong positivists in the USSR. For example, I. A. Poletayev has stated "nothing except prejudice and superstition allow one to deny with assurance today the possibility that the machine will pass, in the end, that limit beyond which consciousness begins" (1958). Other strong positivists include S. L. Sobolev (an Academician and a well-known mathematician) and A. A. Lyapunov (1960). We also find:

. . . Thus, the perfecting of computer machines involuntarily leads us to the need to create a model of the brain. . . . Also, one of the most effective methods of studying intra-cerebral processes involve experiments carried out in electrical models of the brain. . . . But cybernetics has its critics too. These are skeptics. One can find them among scientists and among ordinary citizens, at times also among administrative personnel. These skeptics reject this branch of science and deny it the right of existence. . . . In rejecting this science, they generally state that the very thought of comparing a machine to a human being is an insult (Moiseyev, 1960).

The majority of Soviet workers appear to recognize (implicitly, at least) the continuum discussed in this report, and argue that while there does exist an upper bound above which machines cannot go, it is not possible to determine the location of that bound. For example:

As a result we arrive at the conclusion that a machine can perform all the intellectual human functions which can be formalized But what can be formalized? . . . Upon brief reflection we con-

clude that it is impossible in principle to answer this question (Kolman, 1960).

Where Do the Russians Stand?

First of all, let us look at what they are doing in those disciplines upon which research in artificial intelligence depends: computing devices, mathematics, psychology, and physiology. With respect to computers, I can speak with firsthand knowledge, for, as mentioned earlier, I spent two weeks in 1959 visiting Soviet computer installations. In my opinion, they are somewhat behind us in the actual construction of machines, particularly with respect to input/output equipment and to numbers of machines (Ware, 1960; Feigenbaum, 1961c). However, there is nothing fundamentally lacking in their state of the art. The quantity of machines is not as important to research as an offhand comparison of numbers of machines might indicate, since none of their machines is devoted to such things as social-security records, subscription fulfillment, or airline reservations. In assessing a comparison of this kind, one always wonders how much of the iceberg we do not see. When visiting the IBM plant in California, Khrushchev said about computers, ". . . for the time being we're keeping them a secret."

The Russians started work on computers after we did, but they have certainly narrowed the gap. Furthermore, they are giving high priority to the computing field. In their announcement concerning the decentralization of responsibility for research, an exception was made for computers, along with fusion, space activities, high-temperature metallurgical research, and certain areas of chemistry; these research areas remained centralized under the cognizance of the Academy of Sciences. Of course, the Russians are interested in spurring the computer field for reasons other than intelligent machine research. There is no reason to believe that future Russian research on intelligent machines need be hampered by the computer tools available to them, although machine time is in short supply today.

In mathematics the Russians have had an outstanding reputation for many decades. In computer mathematics I have no doubts that, in general, they excel the West. One of the things which impressed our delegation, and other delegations before ours (Carr *et al.*, 1959), was the number of outstanding mathematicians now working in the computer field. Unfortunately, many U.S. mathematicians view computers as a glorified slide rule of interest only to engineers, or as an expensive sorting device of interest to businessmen with clerical problems.

Since psychological research on mental processes and neurophysiological research on structure and activity of the brain both play a vital suggestive role in the attempt to construct intelligent machines, progress by the Soviets in these disciplines is of considerable interest. Although psychology

was severely inhibited during the Stalin era, a renaissance of impressive proportions has taken place within the last decade. Physiology, less inhibited in the previous era, is in even better shape. The best available evidence indicates that Russian neurophysiology is dynamic, innovative, and up to date. The researchers are competent and generally sophisticated; their laboratories are modern and well equipped.

The Soviets have demonstrated a knack for focusing talent and resources on important applied problems. I believe that the Soviets regard artificial intelligence as one such problem area, and that the best of modern Soviet psychology and neurophysiology will be recruited into the search for solutions. With respect to physiological research, the following is of interest:

Essentially, we (the Western World) have not found the physiochemical principles of neural activity, whereas the Russians have not seriously sought them. However, the current 7-year plan for physiology as presented in a recent editorial by D. A. Biriukev in the Sechenov Physiological Journal of the USSR calls for precisely this goal (Freeman, 1960).

A recent visitor of the USSR reports that Soviet physiologists appear to be under pressure to produce explanations for human behavior which can be incorporated into machines. He further reports that their work is apparently under security wraps.

Russian Emphasis on Artificial Intelligence Research

I went to the Soviet Union convinced they were putting a great deal of emphasis on research in artificial intelligence. Possibly this predisposition influenced what I thought I saw. I also want to emphasize that *I was impressed, not by any substantive results, but by their apparent conviction that this was an important research area.*

In one institute, in response to my question about the problem of simulating the brain with a computer, I was told "It is considered *the* number one problem." The emphasis on "the" was the speaker's; the statement was made in English. At another institute, when Professor L. I. Gutenmacher, head of the Laboratory for Electrical Modeling, told us that the charter of his laboratory was the modeling of human mental processes, I asked him if he had difficulty obtaining financial support for such exotic research. His response was "No, not at all; the President of the Academy of Sciences is convinced that this is an important field for research." There is evidence that he has been given ample support. I was told that his laboratory, which was formerly (and still is ostensibly) a part of the Institute of Scientific Information, had all the status of an institute, being separately funded and reporting directly to the Presidium

of the Academy of Sciences. Gutenmacher's laboratory is apparently responsible for mechanizing the functions of the Institute of Scientific Information, which is a large, centralized, information retrieval system for scientific information from all over the world.

Despite much effort, our delegation was unable to visit Gutenmacher's laboratory. To my knowledge, no Westerner has done so; in fact none had met Gutenmacher before our delegation. Some in the U.S. have concluded from this denial of entry to his laboratory that there was nothing to be shown. However, its work may be classified, as Khrushchev indicated. But whether or not anything is being accomplished is not pertinent to the point that the President of the Soviet Academy of Sciences, a man with much power and resources, believes that modeling human mental activities is possible, that he recognizes the importance of research in this field, and that he is devoting considerable resources to this end.

What are some of the other indications about Soviet attitudes toward research on intelligent machines? As previously mentioned, cybernetics is a household word in Russia. Much is being written on the subject, in journals and in the popular press. There appears to be an effort in the popular writings to legitimize such research as being in harmony with communism. For example, recall the earlier quote about Marx (Klaus, 1960).

With respect to professional writing on machine intelligence, a journal entitled *Problems of Cybernetics* was started in 1958; seven hard-cover volumes have appeared to date (Lyapunov, 1960, 1961). Since 1955, seminars on cybernetics have been held at the University of Moscow. These seminars are aimed at bringing together scientists from various disciplines. Similarly, the editors of *Problems of Cybernetics* state that their aim "is the unification of the scientific interests of those working in different fields of science concerned with cybernetics."

There seems to be widespread recognition for the necessity of an interdisciplinary approach to problems of cybernetics. Article after article appeals to personnel from the various disciplines to get together. How much effect these appeals and seminars have is unknown. During our visit to the Soviet Union, we were told that some 500 physicists had been transferred to the biological sciences. We talked with I. M. Gelfand, a world-famous mathematician now working in the physiological field. He began studying the brain but switched to the heart, which he believes to be much simpler. With knowledge gained from studying the heart, he will return to the study of the brain. We were also told that other mathematicians were working on psychological and physiological problems.

Within the Soviet Academy of Sciences, there exists a "Scientific Council on Cybernetics." This council is headed by A. I. Berg and apparently reports directly to the Presidium of the Academy (Berg, 1960). To my

knowledge, there is no evidence of any effect this council may be having in coordinating, controlling, or encouraging research in cybernetics. Outside of Moscow, individual researchers appear to operate entirely on their own, with little communication with other such researchers, and with only meager support. However, one does occasionally encounter references to the formation of new groups and laboratories for such work.

There is some evidence that machine time (until recently in critically short supply) has been made available for work in this area. *Moscow News* of August 12, 1961, has an article on musical composition and medical diagnosis on a computer while the issue of September 2, 1961, discusses chess playing by machines and the deciphering of ancient Mayan manuscripts.

In closing this topic, a quotation which appeared in the February, 1959, issue of *Fortune* is pertinent. Frank Pace, Jr., then president of General Dynamics Corporation, in warning us not to overlook nor be surprised by Russia's capacity to concentrate in specific areas, said:

If the area has real military or psychological value to them, they'll put massive concentration on it, and achieve results all out of proportion to the general level of their technical ability.

The Importance of Research in Artificial Intelligence

I have indicated my feeling that research aimed at pushing machines further out in the continuum of intelligence is very important. Today's computers are helping advance the frontiers of man's knowledge in many fields; computers now pervade almost all scientific disciplines. (The fact that they pervade the field of research on intelligent machines means that such research will feed on itself.) The use of computers in research has been a key factor in the explosion of knowledge we have witnessed in the last decade. Their contribution to date has stemmed largely from their speed in doing arithmetic and the reliability with which they do it. As we move out in the continuum of possibilities, new dimensions and contributions will become important. A machine which retrieves information from a large store by complex associative processes like those inherent in Willis Ware's output of "Frizell," but which exceeds Dr. Ware in speed, reliability, and memory capacity, would be crucial in aiding scientists to cope with the flood of research results presently inundating science.

The large amount of money spent on machines today is evidence of the value placed on the computers' abilities along the dimensions of speed and reliability. If the machine's capabilities can be extended in additional dimensions, would it not be of great importance? Suppose that the boundary (if it exists at all) beyond which machines cannot go lies fairly close to the human brain in the dimension related to the sophistication of

the information processing techniques used. Since it is known that the machine can exceed the human in speed and reliability, and probably in amount of memory, such a machine would approach the status of being "super-human." Of course, this is speculation; the boundary may be much lower.

We have been examining the question of the technological importance of research in artificial intelligence in the context of advancing the frontiers of knowledge for the sake of technological and scientific advancement. In such a context, there is little cause for any concern or action; progress in the field is being made at a fairly rapid pace in this country. However, since we are engaged in a technological race with the USSR, action becomes important, particularly since, in my opinion, the Russians appear to be putting much more emphasis on research in artificial intelligence than we are. Even if the Russians were not competing in this particular event of the "technological Olympics," it is an event well worth the running in that we will learn more about man and in that better machines will contribute to advancing the frontiers of knowledge in almost every discipline.

Timing

Before closing, a comment on the question "when?" It is one thing to say it is possible to push machine capabilities way out in the continuum of intelligence, but it is another thing to say when. It was over four hundred years from da Vinci to the Wright brothers. But the sands of time in the scientific world have been flowing much more rapidly of late. Advances now made in a decade compare with earlier steps which took a century. Few would have believed in 1950 that man would hit the moon with a rocket within ten years. Gutenmacher, when told recently of the Simon and Newell prediction that a machine would be chess champion within ten years (Newell and Simon, 1958*d*) said that he thought the prediction conservative; it would happen sooner.

Conclusion

It is hoped that the definition of research on artificial intelligence as an effort to push machines further out in the continuum of intelligent behavior will reduce some of the semantic difficulties surrounding discussions of such research. I feel that such research is very important to our country and that we must expand our efforts therein. To do so implies that more researchers from the related disciplines are needed. The success of our efforts will depend on how well we do in bringing the various disciplines together and on the number of well-qualified scientists who are attracted to this research area.

STEPS TOWARD ARTIFICIAL INTELLIGENCE

by Marvin Minsky

Introduction

A visitor to our planet might be puzzled about the role of computers in our technology. On the one hand, he would read and hear all about wonderful "mechanical brains" baffling their creators with prodigious intellectual performance. And he (or it) would be warned that these machines must be restrained, lest they overwhelm us by might, persuasion, or even by the revelation of truths too terrible to be borne. On the other hand, our visitor would find the machines being denounced, on all sides, for their slavish obedience, unimaginative literal interpretations, and incapacity for innovation or initiative; in short, for their inhuman dullness.

Our visitor might remain puzzled if he set out to find, and judge for himself, these monsters. For he would find only a few machines (mostly "general-purpose" computers, programmed for the moment to behave according to some specification) doing things that might claim any real intellectual status. Some would be proving mathematical theorems of rather undistinguished character. A few machines might be playing certain games, occasionally defeating their designers. Some might be distinguishing between hand-printed letters. Is this enough to justify so much interest, let alone deep concern? I believe that it is; that we are on the threshold of an era that will be strongly influenced, and quite possibly dominated, by intelligent problem-solving machines. But our purpose is not to guess about what the future may bring; it is only to try to describe and explain what seem now to be our first steps toward the construction of "artificial intelligence."

Along with the development of general-purpose computers, the past few years have seen an increase in effort toward the discovery and mechanization of problem-solving processes. Quite a number of papers have appeared describing theories or actual computer programs concerned with game playing, theorem proving, pattern recognition, and other domains which would seem to require some intelligence. The literature does not include any general discussion of the outstanding problems of this field.

In this article, an attempt will be made to separate out, analyze, and find the relations between some of these problems. Analysis will be supported with enough examples from the literature to serve the introductory function of a review article, but there remains much relevant work not described here. This report is highly compressed, and therefore, cannot begin to discuss all these matters in the available space.

There is, of course, no generally accepted theory of "intelligence"; the analysis is our own and may be controversial. We regret that we cannot give full personal acknowledgments here—suffice it to say that we have discussed these matters with almost every one of the cited authors.

It is convenient to divide the problems into five main areas: Search, Pattern Recognition, Learning, Planning, and Induction; these comprise the main divisions of the report. Let us summarize, the entire argument very briefly:

A computer can do, in a sense, only what it is told to do. But even when we do not know exactly how to solve a certain problem, we may program a machine to *Search* through some large space of solution attempts. Unfortunately, when we write a straightforward program for such a search, we usually find the resulting process to be enormously inefficient. With *Pattern Recognition* techniques, efficiency can be greatly improved by restricting the machine to use its methods only on the kind of attempts for which they are appropriate. And with *Learning*, efficiency is further improved by directing Search in accord with earlier experiences. By actually analyzing the situation, using what we call *Planning* methods, the machine may obtain a really fundamental improvement by replacing the originally given Search by a much smaller, more appropriate exploration. Finally, in the section on *Induction*, we consider some rather more global concepts of how one might obtain intelligent machine behavior.

1. *The Problem of Search*¹

If, for a given problem, we have a means for checking a proposed solution, then we can solve the problem by testing all possible answers. But this

¹ The adjective "heuristic," as used here and widely in the literature, means *related to improving problem-solving performance*; as a noun it is also used in regard to any method or trick used to improve the efficiency of a problem-solving system. A

always takes much too long to be of practical interest. Any device that can reduce this search may be of value. If we can detect relative improvement, then "hill-climbing" (Sec. I-B) may be feasible, but its use requires some structural knowledge of the search space. And unless this structure meets certain conditions, hill-climbing may do more harm than good.

When we talk of problem-solving in what follows we will usually suppose that all the problems to be solved are initially *well defined* (McCarthy, 1956). By this we mean that with each problem we are given some systematic way to decide when a proposed solution is acceptable. Most of the experimental work discussed here is concerned with such well-defined problems as are met in theorem-proving, or in games with precise rules for play and scoring.

In one sense all such problems are trivial. For if there exists a solution to such a problem, that solution can be found eventually by any blind exhaustive process which searches through all possibilities. And it is usually not difficult to mechanize or program such a search.

But for any problem worthy of the name, the search through all possibilities will be too inefficient for practical use. And on the other hand, systems like chess, or nontrivial parts of mathematics, are too complicated for complete analysis. Without complete analysis, there must always remain some core of search, or "trial and error." So we need to find techniques through which the results of *incomplete analysis* can be used to make the search more efficient. The necessity for this is simply overwhelming: a search of all the paths through the game of checkers involves some 10^{40} move choices (Samuel, 1959a), in chess, some 10^{120} (Shannon, in Newman, 1956). If we organized all the particles in our galaxy into some kind of parallel computer operating at the frequency of hard cosmic rays, the latter computation would still take impossibly long; we cannot expect improvements in "hardware" alone to solve all our problems! Certainly we must use whatever we know in advance to guide the trial generator. And we must also be able to make use of results obtained along the way.^{2,3}

"heuristic program," to be considered successful, must work well on a variety of problems, and may often be excused if it fails on some. We often find it worthwhile to introduce a heuristic method which happens to cause occasional failures, if there is an over-all improvement in performance. But imperfect methods are not necessarily heuristic, nor vice versa. Hence "heuristic" should not be regarded as opposite to "foolproof"; this has caused some confusion in the literature.

² McCarthy (1956) has discussed the enumeration problem from a recursive-function-theory point of view. This incomplete but suggestive paper proposes, among other things, that "the enumeration of partial recursive functions should give an early place to compositions of functions that have already appeared."

I regard this as an important notion, especially in the light of Shannon's results (1949) on two-terminal switching circuits—that the "average" n -variable switching

A. Relative Improvement, Hill-climbing, and Heuristic Connections

A problem can hardly come to interest us if we have no background of information about it. We usually have some basis, however flimsy, for detecting *improvement*; some trials will be judged more successful than others. Suppose, for example, that we have a *comparator* which selects as the better, one from any pair of trial outcomes. Now the comparator cannot, alone, serve to make a problem well defined. No goal is defined. But if the comparator-defined relation between trials is "transitive" (*i.e.*, if *A* dominates *B* and *B* dominates *C* implies that *A* dominates *C*), then we can at least define "progress," and ask our machine, given a time limit, to do the best it can.

But it is essential to observe that a comparator by itself, however shrewd, cannot alone give any improvement over exhaustive search. The comparator gives us information about partial success, to be sure. But we need also some way of using this information to direct the pattern of search in promising directions; to select new trial points which are in some sense "like," or "similar to," or "in the same direction as" those which have given the best previous results. To do this we need some additional structure on the search space. This structure need not bear much resemblance to the ordinary spatial notion of direction, or that of distance, but it must somehow tie together points which are heuristically related.

We will call such a structure a *heuristic connection*. We introduce this term for informal use only—that is why our definition is itself so informal. But we need it. Many publications have been marred by the misuse, for this purpose, of precise mathematical terms, *e.g.*, *metric* and *topological*. The term "connection," with its variety of dictionary meanings, seems just the word to designate a relation without commitment as to the exact nature of the relation.

An important and simple kind of heuristic connection is that defined when a space has coordinates (or parameters) and there is also defined a numerical "success function" *E* which is a reasonably smooth function of the coordinates. Here we can use local optimization or *hill-climbing* methods.

function requires about $2^n/n$ contacts. This disaster does not usually strike when we construct "interesting" large machines, presumably because they are based on composition of functions already found useful. One should not overlook the pioneering paper of Newell (1955), and Samuel's discussion of the minimaxing process in (1959a).

³In 1952 and especially in 1956, Ashby has an excellent discussion of the search problem. (However, I am not convinced of the usefulness of his notion of "ultra-stability," which seems to be little more than the property of a machine to search until something stops it.)

B. Hill-climbing

Suppose that we are given a black-box machine with inputs $\lambda_1, \dots, \lambda_n$ and an output $E(\lambda_1, \dots, \lambda_n)$. We wish to maximize E by adjusting the input values. But we are not given any mathematical description of the function E ; hence we cannot use differentiation or related methods. The obvious approach is to explore locally about a point, finding the direction of steepest ascent. One moves a certain distance in that direction and repeats the process until improvement ceases. If the hill is smooth this may be done, approximately, by estimating the gradient component $\partial E/\partial \lambda_i$ separately for each coordinate λ_i . There are more sophisticated approaches (one may use noise added to each variable, and correlate the output with each input, see Fig. 1), but this is the general idea. It is a fundamental technique, and we see it always in the background of far more complex systems. Heuristically, its great virtue is this: the sampling effort (for determining the direction of the gradient) grows, in a sense, only linearly with the number of parameters. So if we can solve, by such a method, a certain kind of problem involving many parameters, then the addition of more parameters of the same kind ought not cause an inordinate increase in difficulty. We are particularly interested in problem-solving methods which can be so extended to more difficult problems. Alas, most interesting systems which involve combinational operations usually grow exponentially more difficult as we add variables.

A great variety of hill-climbing systems have been studied under the names of "adaptive" or "self-optimizing" servomechanisms.

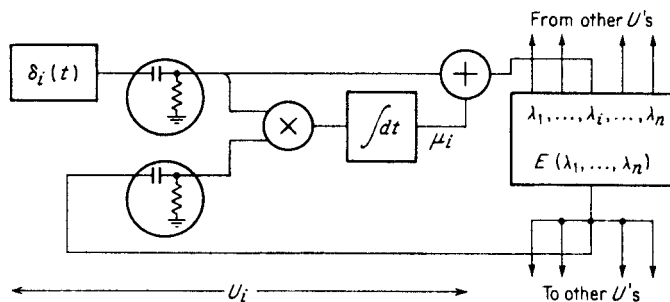

Figure 1. "Multiple simultaneous optimizers" search for a (local) maximum value of some function $E(\lambda_1, \dots, \lambda_n)$ of several parameters. Each unit U_i independently "jitters" its parameter λ_i , perhaps randomly, by adding a variation $\delta_i(t)$ to a current mean value μ_i . The changes in the quantities δ_i and E are correlated, and the result is used to (slowly) change μ_i . The filters are to move d-c components. This simultaneous technique, really a form of coherent detection, usually has an advantage over methods dealing separately and sequentially with each parameter. [Cf. the discussion of "informative feedback" in Wiener (1948, pp. 133f.).]

C. Troubles with Hill-climbing

Obviously, the gradient-following hill-climber would be trapped if it should reach a *local peak* which is not a true or satisfactory optimum. It must then be forced to try larger steps or changes.

It is often supposed that this false-peak problem is the chief obstacle to machine learning by this method. This certainly can be troublesome. But for really difficult problems, it seems to us that usually the more fundamental problem lies in finding any significant peak at all. Unfortunately the known *E* functions for difficult problems often exhibit what we have called (Minsky and Selfridge, 1960) the "*Mesa Phenomenon*" in which a small change in a parameter usually leads to either no change in performance or to a large change in performance. The space is thus composed primarily of flat regions or "mesas." Any tendency of the trial generator to make small steps then results in much aimless wandering without compensating information gains. A profitable search in such a space requires steps so large that hill-climbing is essentially ruled out. The problem-solver must find other methods; hill-climbing might still be feasible with a different heuristic connection.

Certainly, in our own intellectual behavior we rarely solve a tricky problem by a steady climb toward success. I doubt that in any one simple mechanism, *e.g.*, hill-climbing, will we find the means to build an efficient and general problem-solving machine. Probably, an intelligent machine will require a variety of different mechanisms. These will be arranged in hierarchies, and in even more complex, perhaps recursive, structures. And perhaps what amounts to straightforward hill-climbing on one level may sometimes appear (on a lower level) as the sudden jumps of "insight."

II. The Problem of Pattern Recognition

In order not to try all possibilities, a resourceful machine must classify problem situations into categories associated with the domains of effectiveness of the machine's different methods. These pattern-recognition methods must extract the heuristically significant features of the objects in question. The simplest methods simply match the objects against standards or prototypes. More powerful "property-list" methods subject each object to a sequence of tests, each detecting some *property* of heuristic importance. These properties have to be invariant under commonly encountered forms of distortion. Two important problems arise here—inventing new useful properties, and combining many properties to form a recognition system. For complex problems, such methods will have to be augmented by facilities for subdividing complex objects and describing the complex relations between their parts.

Any powerful heuristic program is bound to contain a variety of different methods and techniques. At each step of the problem-solving process the machine will have to decide what aspect of the problem to work on, and then which method to use. A choice must be made, for we usually cannot afford to try all the possibilities. In order to deal with a goal or a problem, that is, to choose an appropriate method, we have to recognize what kind of thing it is. Thus the need to choose among actions compels us to provide the machine with classification techniques, or means of evolving them. It is of overwhelming importance that the machine have classification techniques which are realistic. But "realistic" can be defined only with respect to the environments to be encountered by the machine, and with respect to the methods available to it. Distinctions which cannot be exploited are not worth recognizing. And methods are usually worthless without classification schemes which can help decide when they are applicable.

A. Teleological Requirements of Classification

The useful classifications are those which match the goals and methods of the machine. The objects grouped together in the classifications should have something of heuristic value in common; they should be "similar" in a useful sense; they should depend on relevant or essential features. We should not be surprised, then, to find ourselves using inverse or teleological expressions to define the classes. We really do want to have a grip on "the class of objects which can be transformed into a result of form Y ," that is, the class of objects which will satisfy some goal. One should be wary of the familiar injunction against using teleological language in science. While it is true that talking of goals in some contexts may dispose us towards certain kinds of animistic explanations, this need not be a bad thing in the field of problem-solving; it is hard to see how one can solve problems without thoughts of purposes. The real difficulty with teleological definitions is technical, not philosophical, and arises when they have to be used and not just mentioned. One obviously cannot afford to use for classification a method which actually requires waiting for some remote outcome, if one needs the classification precisely for deciding whether to try out that method. So, in practice, the ideal teleological definitions often have to be replaced by practical approximations, usually with some risk of error; that is, the definitions have to be made *heuristically effective*, or economically usable. This is of great importance. (We can think of "heuristic effectiveness" as contrasted to the ordinary mathematical notion of "effectiveness" which distinguishes those definitions which can be realized at all by machine, regardless of efficiency.)

B. Patterns and Descriptions

It is usually necessary to have ways of assigning *names*—symbolic expressions—to the defined classes. The structure of the names will have a

crucial influence on the mental world of the machine, for it determines what kinds of things can be conveniently thought about. There are a variety of ways to assign names. The simplest schemes use what we will call *conventional* (or *proper*) names; here, arbitrary symbols are assigned to classes. But we will also want to use complex *descriptions* or *computed names*; these are constructed for classes by processes which *depend on the class definitions*. To be useful, these should reflect some of the structure of the things they designate, abstracted in a manner relevant to the problem area. The notion of description merges smoothly into the more complex notion of *model*; as we think of it, a model is a sort of active description. It is a thing whose form reflects some of the structure of the thing represented, but which also has some of the character of a working machine.

In Sec. III we will consider "learning" systems. The behavior of those systems can be made to change in reasonable ways depending on what happened to them in the past. But by themselves, the simple learning systems are useful only in recurrent situations; they cannot cope with any significant novelty. Nontrivial performance is obtained only when learning systems are supplemented with classification or pattern-recognition methods of some inductive ability. For the variety of objects encountered in a nontrivial search is so enormous that we cannot depend on recurrence, and the mere accumulation of records of past experience can have only limited value. Pattern Recognition, by providing a heuristic connection which links the old to the new, can make learning broadly useful.

What is a "pattern"? We often use the term teleologically to mean a set of objects which can in some (useful) way be treated alike. For each problem area we must ask, "What patterns would be useful for a machine working on such problems?"

The problems of *visual* pattern recognition have received much attention in recent years and most of our examples are from this area.

C. Prototype-derived Patterns

The problem of reading *printed* characters is a clearcut instance of a situation in which the classification is based ultimately on a fixed set of "prototypes"—*e.g.*, the dies from which the type font was made. The individual marks on the printed page may show the results of many distortions. Some distortions are rather systematic: change in size, position, orientation. Some are of the nature of noise: blurring, grain, low contrast, etc.

If the noise is not too severe, we may be able to manage the identification by what we call a *normalization and template-matching* process. We first remove the differences related to size and position—that is, we *normalize* the input figure. One may do this, for example, by constructing a similar figure inscribed in a certain fixed triangle (see Fig. 2); or one may transform the figure to obtain a certain fixed center of gravity and a unit second central moment. [There is an additional problem with rotational

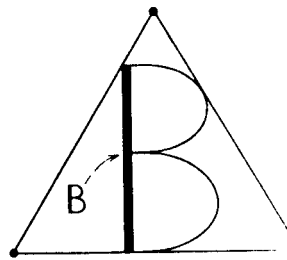

Figure 2. A simple normalization technique. If an object is expanded uniformly, without rotation, until it touches all three sides of a triangle, the resulting figure will be unique, and pattern recognition can proceed without concern about relative size and position.

equivalence where it is not easy to avoid all ambiguities. One does not want to equate "6" and "9." For that matter, one does not want to equate $(0,0)$, or (X,x) or the o 's in x_0 and x^0 , so that there may be context dependency involved.] Once normalized, the unknown figure can be compared with *templates* for the prototypes and, by means of some measure of *matching*, choose the best fitting template. Each "matching criterion" will be sensitive to particular forms of noise and distortion, and so will each normalization procedure. The inscribing or boxing method may be sensitive to small specks, while the moment method will be especially sensitive to smearing, at least for thin-line figures, etc. The choice of a matching criterion must depend on the kinds of noise and transformations commonly encountered.

Still, for many problems we may get acceptable results by using straightforward correlation methods.

When the class of equivalence transformations is very large, *e.g.*, when local stretching and distortion are present, there will be difficulty in finding a uniform normalization method. Instead, one may have to consider a process of adjusting locally for best fit to the template. (While measuring the matching, one could "jitter" the figure locally; if an improvement were found the process could be repeated using a slightly different change, etc.) There is usually no practical possibility of applying to the figure *all* of the admissible transformations. And to recognize the *topological* equivalence of pairs such as those in Fig. 3 is likely beyond any practical kind of iterative local-improvement or hill-climbing matching procedure. (Such recognitions can be mechanized, though, by methods which follow lines, detect vertices, and build up a *description* in the form, say, of a vertex-connection table.)

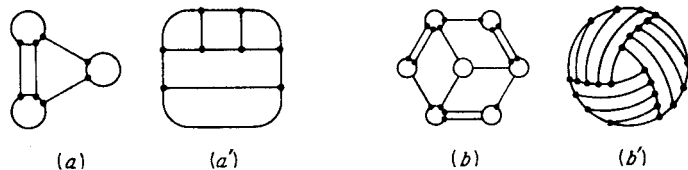

Figure 3. The figures A , A' and B , B' are topologically equivalent pairs. Lengths have been distorted in an arbitrary manner, but the connectivity relations between corresponding points have been preserved. In Sherman (1959) and Haller (1959) we find computer programs which can deal with such equivalences.

The template-matching scheme, with its normalization and direct comparison and matching criterion, is just too limited in conception to be of much use in more difficult problems. If the transformation set is large, normalization, or "fitting," may be impractical, especially if there is no adequate heuristic connection on the space of transformations. Furthermore, for each defined pattern, the system has to be presented with a prototype. But if one has in mind a fairly abstract class, one may simply be unable to represent its essential features with one or a very few concrete examples. How could one represent with a single prototype the class of figures which have an even number of disconnected parts? Clearly, the template system has negligible descriptive power. The property-list system frees us from some of these limitations.

D. Property Lists and "Characters"

We define a *property* to be a two-valued function which divides figures into two classes; a figure is said to have or not have the property according to whether the function's value is 1 or 0. Given a number *N* of distinction properties, we could define as many as 2^N subclasses by their set intersections and, hence, as many as 2^{2^N} *patterns* by combining the properties with AND's and OR's. Thus, if we have three properties, *rectilinear*, *connected*, and *cyclic*, there are eight subclasses (and 256 patterns) defined by their intersections (see Fig. 4).

If the given properties are placed in a fixed order then we can represent any of these elementary regions by a vector, or string of digits. The vector so assigned to each figure will be called the *Character* of that figure (with respect to the sequence of properties in question). [In "Some Aspects of Heuristic Programming and Artificial Intelligence" (1959a), we use the

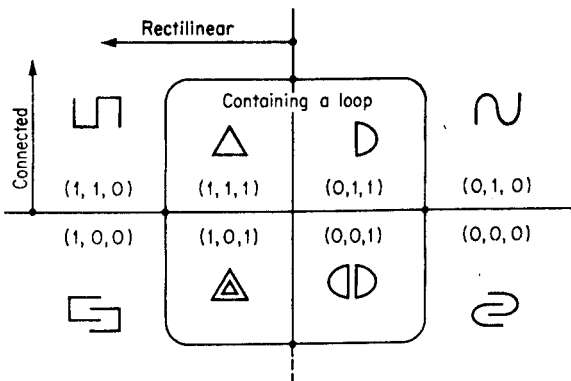

Figure 4. The eight regions represent all the possible configurations of values of the three properties "rectilinear," "connected," "containing a loop." Each region contains a representative figure, and its associated binary "Character" sequence.

term *characteristic* for a property without restriction to 2 values.] Thus a square has the Character (1,1,1) and a circle the Character (0,1,1) for the given sequence of properties.

For many problems one can use such Characters as names for categories and as primitive elements with which to define an adequate set of patterns. Characters are more than conventional names. They are instead very rudimentary forms of description (having the form of the simplest symbolic expression—the *list*) whose structure provides some information about the designated classes. This is a step, albeit a small one, beyond the template method; the Characters are not simple instances of the patterns, and the properties may themselves be very abstract. Finding a good set of properties is the major concern of many heuristic programs.

E. Invariant Properties

One of the prime requirements of a good property is that it be invariant under the commonly encountered equivalence transformations. Thus for visual Pattern Recognition we would usually want the object identification to be independent of uniform changes in size and position. In their pioneering paper Pitts and McCulloch (1947) describe a general technique for forming invariant properties from noninvariant ones, assuming that the transformation space has a certain (group) structure. The idea behind their mathematical argument is this: suppose that we have a function P of figures, and suppose that for a given figure F we define $[F] = \{F_1, F_2, \dots\}$ to be the set of all figures equivalent to F under the given set of transformations; further, define $P[F]$ to be the set $\{P(F_1), P(F_2), \dots\}$ of values of P on those figures. Finally, define $P^*[F]$ to be AVERAGE ($P[F]$). Then we have a new property P^* whose values are independent of the selection of F from an equivalence class defined by the transformations. We have to be sure that when different representatives are chosen from a class the collection $[F]$ will always be the same in each case. In the case of continuous transformation spaces, there will have to be a *measure* or the equivalent associated with the set $[F]$ with respect to which the operation AVERAGE is defined, say, as an integration.⁴

This method is proposed (Pitts and McCulloch, 1947) as a neurophysiological model for pitch-invariant hearing and size-invariant visual

⁴In the case studied in Pitts and McCulloch (1947) the transformation space is a *group* with a uniquely defined measure: the set $[F]$ can be computed without repetitions by scanning through the application of all the transforms T_α to the given figure so that the invariant property can be defined by

$$P^*(F) = \int_{\alpha \in G} P(T_\alpha(F)) d\mu$$

where G is the group and μ the measure. By substituting $T_\beta(F)$ for F in this, one can see that the result is independent of choice of β since we obtain the same integral over $G\beta^{-1} = G$.

recognition (supplemented with visual centering mechanisms). This model is discussed also by Wiener.⁵ Practical application is probably limited to one-dimensional groups and analog scanning devices.

In much recent work this problem is avoided by using properties already invariant under these transformations. Thus a property might count the number of connected components in a picture—this is invariant under size and position. Or a property may count the number of vertical lines in a picture—this is invariant under size and position (but not rotation).

F. Generating Properties

The problem of generating useful properties has been discussed by Selfridge (1955); we shall summarize his approach. The machine is given, at the start, a few basic transformations A_1, \dots, A_n , each of which transforms, in some significant way, each figure into another figure. A_1 might, for example, remove all points *not on a boundary* of a solid region; A_2 might leave only *vertex* points; A_3 might *fill up hollow regions*, etc. (see Fig. 5). Each sequence $A_{i_1}A_{i_2} \dots A_{i_k}$ of these forms a new transformation, so that there is available an infinite variety. We provide the machine also with one or more "terminal" operations which convert a picture into a number, so that any sequence of the elementary transformations, followed by a terminal operation, defines a property. [Dineen (1955) describes how these processes were programmed in a digital computer.] We can start with a few short sequences, perhaps chosen randomly. Selfridge describes how the machine might learn new useful properties.

We now feed the machine A's and O's telling the machine each time which letter it is. Beside each sequence under the two letters, the machine builds up distribution functions from the results of applying the sequences to the image. Now, since the sequences were chosen completely randomly, it may well be that most of the sequences have very flat distribution functions; that is, they [provide] no information,

⁵ See pp. 160ff. of Wiener (1948).

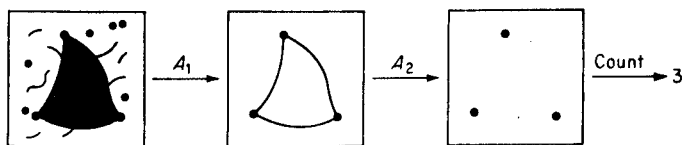

Figure 5. An arbitrary sequence of picture transformations, followed by a numerical-valued function, can be used as a *property* function for pictures. A_1 removes all points which are not at the edge of a solid region. A_2 leaves only vertex points—at which an arc suddenly changes direction. The function C simply counts the number of points remaining in the picture. All remarks in the text could be generalized to apply to properties like A_1A_2C , which can have more than two values.

and the sequences are therefore [by definition] not significant. Let it discard these and pick some others. Sooner or later, however, some sequences will prove significant; that is, their distribution functions will peak up somewhere. What the machine does now is to build up new sequences like the significant ones. This is the important point. If it merely chose sequences at random it might take a very long while indeed to find the best sequences. But with some successful sequences, or partly successful ones, to guide it, we hope that the process will be much quicker. The crucial question remains: how do we build up sequences "like" other sequences, but not identical? As of now we think we shall merely build sequences from the transition frequencies of the significant sequences. We shall build up a matrix of transition frequencies from the significant ones, and use those as transition probabilities with which to choose new sequences.

We do not claim that this method is necessarily a very good way of choosing sequences—only that it should do better than not using at all the knowledge of what kind of sequences has worked. It has seemed to us that this is the crucial point of learning.⁶

It would indeed be remarkable if this failed to yield properties more useful than would be obtained from completely random sequence selection. The generating problem is discussed further in Minsky (1956a). Newell, Shaw, and Simon (1960b) describe more deliberate, less statistical, techniques that might be used to discover sets of properties appropriate to a given problem area. One may think of the Selfridge proposal as a system which uses a finite-state language to describe its properties. Solomonoff (1957, 1960) proposes some techniques for discovering common features of a set of expressions, *e.g.*, of the descriptions of those properties of already established utility; the methods can then be applied to generate new properties with the same common features. I consider the lines of attack in Selfridge (1955), Newell, Shaw and Simon (1960a), and Solomonoff (1960, 1958), although still incomplete, to be of the greatest importance.

G. Combining Properties

One cannot expect easily to find a *small* set of properties which will be just right for a problem area. It is usually much easier to find a large set of properties each of which provides a little useful information. Then one is faced with the problem of finding a way to combine them to make the desired distinctions. The simplest method is to choose, for each class, a typical character (a particular sequence of property values) and then to use some matching procedure, *e.g.*, counting the numbers of agreements and disagreements, to compare an unknown with these chosen "Character

⁶ See p. 93 of Selfridge (1955).

prototypes." The linear weighting scheme described just below is a slight generalization on this. Such methods treat the properties as more or less independent evidence for and against propositions; more general procedures (about which we have yet little practical information) must account also for nonlinear relations between properties, *i.e.*, must contain weighting terms for joint subsets of property values.

1. "BAYES NETS" FOR COMBINING INDEPENDENT PROPERTIES

We consider a single experiment in which an object is placed in front of a property-list machine. Each property E_i will have a value, 0 or 1. Suppose that there has been defined some set of "object classes" F_j , and that we want to use the outcome of this experiment to decide in which of these classes the object belongs.

Assume that the situation is basically probabilistic, and that we know the probability p_{ij} that, if the object is in class F_j then the i th property E_i will have value 1. Assume further that these properties are independent; that is, even given F_j , knowledge of the value of E_i tells us nothing more about the value of a different E_k in the same experiment. (This is a strong condition—see below.) Let ϕ_j be the absolute probability that an object is in class F_j . Finally, for this experiment define V to be the particular set of i 's for which the E_i 's are 1. Then this V represents the Character of the object. From the definition of conditional probability, we have

$$\Pr(F_j, V) = \Pr(V) \cdot \Pr(F_j|V) = \Pr(F_j) \cdot \Pr(V|F_j)$$

Given the Character V , we want to guess which F_j has occurred (with the least chance of being wrong—the so-called *maximum likelihood estimate*); that is, for which j is $\Pr(F_j|V)$ the largest? Since in the above $\Pr(V)$ does not depend on j , we have only to calculate for which j is

$$\Pr(F_j) \cdot \Pr(V|F_j) = \phi_j \Pr(V|F_j)$$

the largest. Hence, by our independence hypothesis, we have to maximize

$$\phi_j \cdot \prod_{i \in V} p_{ij} \cdot \prod_{i \in \bar{V}} q_{ij} = \phi_j \prod_{i \in V} \frac{p_{ij}}{q_{ij}} \cdot \prod_{\text{all } i} q_{ij} \quad (1)$$

These "maximum-likelihood" decisions can be made (Fig. 6) by a simple network device.⁷

⁷ At the cost of an additional network layer, we may also account for the possible cost g_{jk} that would be incurred if we were to assign to F_k a figure really in class F_j ; in this case the minimum cost decision is given by the k for which

$$\sum_j g_{jk} \phi_j \prod_{i \in V} p_{ij} \prod_{i \in \bar{V}} q_{ij}$$

is the least. \bar{V} is the complement set to V . q_{ij} is $(1 - p_{ij})$.

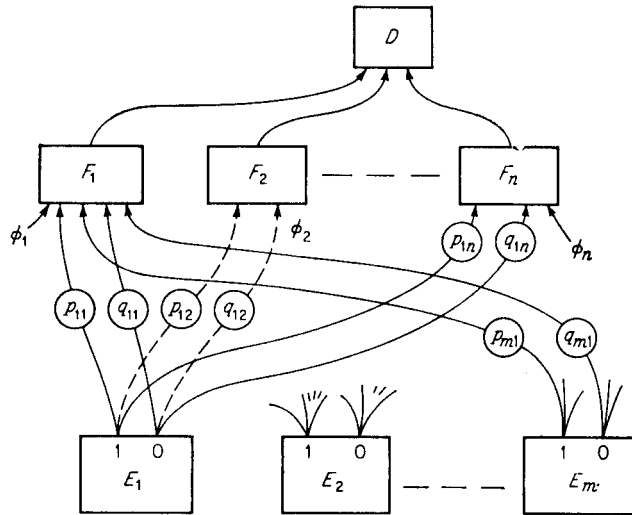

Figure 6. "Net" model for maximum-likelihood decisions based on linear weightings of property values. The input data are examined by each "property filter" E_i . Each E_i has "0" and "1" output channels, one of which is excited by each input. These outputs are weighted by the corresponding p_{ij} 's, as shown in the text. The resulting signals are multiplied in the F_j units, each of which "collects evidence" for a particular figure class. [We could have used here $\log(p_{ij})$, and added at the F_j units.] The final decision is made by the topmost unit D , who merely chooses that F_j with the largest score. Note that the logarithm of the coefficient p_{ij}/q_{ij} in the second expression of (1) can be construed as the "weight of the evidence" of E_i in favor of F_j . [See also Papert (1961) and Rosenblatt (1958).]

These nets resemble the general schematic diagrams proposed in the "Pandemonium" model of Selfridge (1959) (see his fig. 3). It is proposed there that some intellectual processes might be carried out by a hierarchy of simultaneously functioning submachines suggestively called "demons." Each unit is set to detect certain patterns in the activity of others and the output of each unit announces the degree of confidence of that unit that it sees what it is looking for. Our E_i units are Selfridge's "data demons." Our units F_j are his "cognitive demons"; each collects from the abstracted data evidence for a specific proposition. The topmost "decision demon" D responds to that one in the multitude below it whose shriek is the loudest.⁸

It is quite easy to add to this "Bayes network model" a mechanism which will enable it to *learn* the optimal connection weightings. Imagine that, after each event, the machine is told which F_j has occurred; we could implement this by sending back a signal along the connections leading to that F_j unit. Suppose that the connection for p_{ij} (or q_{ij}) contains a two-terminal device (or "synapse") which stores a number w_{ij} . Whenever the joint event ($F_j, E_i = 1$) occurs, we modify w_{ij} by replacing it by

⁸ See also the report in Selfridge and Neisser (1960).

$(w_{ij} + 1)\theta$, where θ is a factor slightly less than unity. And when the joint event ($F_j, E_i = 0$) occurs, we decrement w_{ij} by replacing it with $(w_{ij})\theta$. It is not difficult to show that the expected values of the w_{ij} 's will become proportional to the p_{ij} 's [and, in fact, approach $p_{ij}[\theta/(1 - \theta)]$]. Hence, the machine tends to learn the optimal weighting on the basis of experience. (One must put in a similar mechanism for estimating the ϕ_j 's.) The variance of the normalized weight $w_{ij}[(1 - \theta)/\theta]$ approaches $[(1 - \theta)/(1 + \theta)]p_{ij}q_{ij}$. Thus a small value for θ means rapid learning but is associated with a large variance, hence, with low reliability. Choosing θ close to unity means slow, but reliable, learning. θ is really a sort of memory decay constant, and its choice must be determined by the noise and stability of the environment—much noise requires long averaging times, while a changing environment requires fast adaptation. The two requirements are, of course, incompatible and the decision has to be based on an economic compromise.⁹

2. POSSIBILITIES OF USING RANDOM NETS FOR BAYES DECISIONS

The nets of Fig. 6 are very orderly in structure. Is all this structure necessary? Certainly if there were a great many properties, *each of which provided very little marginal information*, some of them would not be missed. Then one might expect good results with a mere sampling of all the possible connection paths w_{ij} . And one might thus, *in this special situation*, use a random connection net.

The two-layer nets here resemble those of the "Perceptron" proposal of Rosenblatt (1958). In the latter, there is an additional level of connections coming directly from randomly selected points of a "retina." Here the properties, the devices which abstract the visual input data, are simple functions which add some inputs, subtract others, and detect whether the result exceeds a threshold. Equation (1), we think, illustrates what is of value in this scheme. It does seem clear that a maximum-likelihood type of analysis of the output of the property functions can be handled by such nets. But these nets, with their simple, randomly generated, connections can probably never achieve recognition of such patterns as "the class of figures having two separated parts," and they cannot even achieve the effect of template recognition without size and position normalization (unless sample figures have been presented previously in essentially all sizes and positions). For the chances are extremely small of finding, by random methods, enough properties usefully correlated with patterns appreciably more abstract than those of the prototype-derived kind. And these networks can really only separate out (by weighting) information in the individual input properties; they cannot extract further information present in nonadditive form. The "Perceptron" class of machines have facilities neither for obtaining better-than-chance properties nor for assembling

⁹ See also Minsky and Selfridge (1960), and Papert (1961).

better-than-additive combinations of those it gets from random construction.¹⁰

For recognizing *normalized* printed or hand-printed characters, single-point properties do surprisingly well (Highleyman and Kamentsky, 1960); this amounts to just "averaging" many samples. Bledsoe and Browning (1959) claim good results with point-pair properties. Roberts (1960) describes a series of experiments in this general area. Doyle (1959) without normalization but with quite sophisticated properties obtains excellent results; his properties are already substantially size- and position-invariant. A general review of Doyle's work and other pattern-recognition experiments will be found in Selfridge and Neisser (1960).

For the complex discrimination, *e.g.*, between one and two connected objects, the property problem is very serious, especially for long wiggly objects such as are handled by Kirsch (1957). Here some kind of recursive processing is required and combinations of simple properties would almost certainly fail even with large nets and long training.

We should not leave the discussion of some decision net models without noting their important limitations. The hypothesis that, for given j , the p_{ij} represent independent events, is a very strong condition indeed. Without this hypothesis we could still construct maximum-likelihood nets, but we would need an additional layer of cells to represent all of the joint events V ; that is, we would need to know all the $\Pr(F_j|V)$. This gives a general (but trivial) solution, but requires 2^n cells for n properties, which is completely impractical for large systems. What is required is a system which computes some sampling of all the joint conditional probabilities, and uses these to estimate others when needed. The work of Uttley (1956, 1959) bears on this problem, but his proposed and experimental devices do not yet clearly show how to avoid exponential growth.¹¹

H. Articulation and Attention—Limitations of the Property-list Method

Because of its fixed size, the property-list scheme is limited (for any given set of properties) in the detail of the distinctions it can make. Its ability to deal with a compound scene containing several objects is critically weak, and its direct extensions are unwieldy and unnatural. If a machine can recognize a chair and a table, it surely should be able to tell us that "there is a chair and a table." To an extent, we can invent properties which allow some capacity for superposition of object Characters.¹² But there is no way to escape the information limit.

¹⁰ See also Roberts (1960), Papert (1961), and Hawkins (1958). We can find nothing resembling an analysis [see (1) above] in Rosenblatt (1958) or his subsequent publications.

¹¹ See also Papert (1961).

¹² Cf. Mooers' technique of Zato coding (1956a, 1956b).

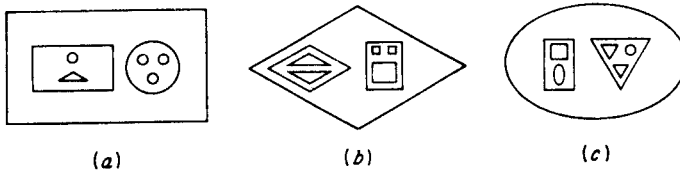

Figure 7. The picture (a) is first described verbally in the text. Then, by introducing notation for the relations "inside of," "to the left of" and "above," we construct a symbolic description. Such descriptions can be formed and manipulated by machines. By abstracting out of the complex relation between the parts of the figure we can use the same formula to describe the related pictures (b) and (c), changing only the list of primitive parts. It is up to the programmer to decide at just what level of complexity a part of a picture should be considered "primitive"; this will depend on what the description is to be used for. We could further divide the drawings into vertices, lines, and arcs. Obviously, for some applications the relations would need more metrical information, e.g., specification of lengths or angles.

What is required is clearly (1) a list (of whatever length is necessary) of the primitive objects in the scene and (2) a statement about the relations among them. Thus we say of Fig. 7a, "A rectangle (1) contains two subfigures disposed horizontally. The part on the left is a rectangle (2) which contains two subfigures disposed vertically; the upper a circle (3) and the lower a triangle (4). The part on the right . . . etc." Such a description entails an ability to separate or "articulate" the scene into parts. (Note that in this example the articulation is essentially recursive; the figure is first divided into two parts; then each part is described using the same machinery.) We can formalize this kind of description in an expression language whose fundamental grammatical form is a pair (R,L) whose first member R names a relation and whose second member L is an ordered list (x₁,x₂, . . . ,x_n) of the objects or subfigures which bear that relation to one another. We obtain the required flexibility by allowing the members of the list L to contain not only the names of "elementary" figures but also "subexpressions" of the form (R,L) designating complex subfigures. Then our scene above may be described by the expression

$$[\odot, (\square, (\rightarrow, \{(\odot, (\square, (\downarrow, (\odot, \Delta))), (\odot, (\odot, (\nabla, (\odot, \odot, \odot))))\})\})]$$

where (⊙, (x,y)) means that y is contained in x; (→,(x,y)) means that y is to the right of x; (↓,(x,y)) means that y is below x, and (Δ,(x,y,z)) means that y is to the right of x and z is underneath and between them. The symbols □, ⊙, and Δ represent the indicated kinds of primitive geometric objects. This expression-pair description language may be regarded as a simple kind of "list-structure" language. Powerful computer techniques have been developed, originally by Newell, Shaw and Simon,

for manipulating symbolic expressions in such languages for purposes of heuristic programming. (See the remarks at the end of Sec. IV. If some of the members of a list are themselves lists, they must be surrounded by exterior parentheses, and this accounts for the accumulation of parentheses.)

It may be desirable to construct descriptions in which the complex relation is extracted, *e.g.*, so that we have an expression of the form FG where F is an expression which at once denotes the composite relation between all the primitive parts listed in G . A complication arises in connection with the "binding" of variables, *i.e.*, in specifying the manner in which the elements of G participate in the relation F . This can be handled in general by the " λ " notation (McCarthy, 1960) but here we can just use integers to order the variables.

For the given example, we could describe the relational part F by an expression

$$\odot(1, \rightarrow(\odot(2, \downarrow(3, 4)), \odot(5, \nabla(6, 7, 8))))$$

in which we now use a "functional notation"; " $(\odot, (x, y))$ " is replaced by " $\odot(x, y)$," etc., making for better readability. To obtain the desired description, this expression has to be applied to an ordered list of primitive objects, which in this case is $(\square, \square, \circ, \Delta, \circ, \circ, \circ, \circ)$. This composite functional form allows us to abstract the composite relation. By changing only the object list we can obtain descriptions also of the objects in Fig. 7b and c.

The important thing about such "articular" descriptions is that they can be obtained by *repeated application of a fixed set of pattern-recognition techniques*. Thus we can obtain *arbitrarily complex* descriptions from a fixed complexity classification mechanism. The new element required in the mechanism (beside the capacity to manipulate the list structures) is the ability to articulate—to "attend fully" to a selected part of the picture and bring all one's resources to bear on that part. In efficient problem-solving programs, we will not usually complete such a description in a single operation. Instead, the depth or detail of description will be under the control of other processes. These will reach deeper, or look more carefully, only when they have to, *e.g.*, when the presently available description is inadequate for a current goal. The author, together with L. Hodes, is working on pattern-recognition schemes using articular descriptions. By manipulating the formal descriptions we can deal with overlapping and incomplete figures, and several other problems of the "Gestalt" type.

It seems likely that as machines are turned toward more difficult problem areas, *passive* classification systems will become less adequate, and we may have to turn toward schemes which are based more on internally

generated hypotheses, perhaps "error-controlled" along the lines proposed by MacKay (1956).

Space requires us to terminate this discussion of pattern-recognition and description. Among the important works not reviewed here should be mentioned those of Bomba (1959) and Grimsdale *et al.* (1959), which involve elements of description, Unger (1959) and Holland (1960) for parallel processing schemes, Hebb (1949) who is concerned with physiological description models, and the work of the Gestalt psychologists, notably Kohler (1947), who have certainly raised, if not solved, a number of important questions. Sherman (1959), Haller (1959) and others have completed programs using line-tracing operations for topological classification. The papers of Selfridge (1955, 1956) have been a major influence on work in this general area.

See also Kirsch *et al.* (1957) for discussion of a number of interesting computer image processing techniques, and see Minot (1959) and Stevens (1957) for reviews of the reading machine and related problems. One should also examine some biological work, *e.g.*, Tinbergen (1951) to see instances in which some discriminations which seem, at first glance very complicated are explained on the basis of a few apparently simple properties arranged in simple decision trees.

III. Learning Systems

In order to solve a new problem, one should first try using methods similar to those that have worked on similar problems. To implement this "basic learning heuristic" one must generalize on past experience, and one way to do this is to use success-reinforced decision models. These learning systems are shown to be averaging devices. Using devices which learn also which events are associated with reinforcement, *i.e.*, reward, we can build more autonomous "secondary reinforcement" systems. In applying such methods to complex problems, one encounters a serious difficulty—in distributing credit for success of a complex strategy among the many decisions that were involved. This problem can be managed by arranging for local reinforcement of partial goals within a hierarchy, and by grading the training sequence of problems to parallel a process of maturation of the machine's resources.

In order to solve a new problem one uses what might be called the basic learning heuristic—first try using methods similar to those which have worked, in the past, on similar problems. We want our machines, too, to benefit from their past experience. Since we cannot expect new situations to be precisely the same as old ones, any useful learning will have to involve generalization techniques. There are too many notions associated

with "learning" to justify defining the term precisely. But we may be sure that any useful learning system will have to use records of the past as *evidence for more general propositions*; it must thus entail some commitment or other about "inductive inference." (See Sec. VB.) Perhaps the simplest way of generalizing about a set of entities is through constructing a new one which is an "ideal," or rather, a typical member of that set; the usual way to do this is to smooth away variation by some sort of averaging technique. And indeed we find that most of the *simple* learning devices do incorporate some averaging technique—often that of averaging some sort of product, thus obtaining a sort of correlation. We shall discuss this family of devices here, and some more abstract schemes in Sec. V.

A. Reinforcement

A reinforcement process is one in which some aspects of the behavior of a system are caused to become more (or less) prominent in the future as a consequence of the application of a "reinforcement operator" Z . This operator is required to affect only those aspects of behavior for which instances have actually occurred recently.

The analogy is with "reward" or "extinction" (not punishment) in animal behavior. The important thing about this kind of process is that it is "operant" [a term of Skinner (1953)]; the reinforcement operator does not initiate behavior, but merely selects that which the Trainer likes from that which has occurred. Such a system must then contain a device M which generates a variety of behavior (say, in interacting with some environment) and a Trainer who makes critical judgments in applying the available reinforcement operators. (See Fig. 8.)

Let us consider a very simple reinforcement model. Suppose that on each presentation of a stimulus S an animal has to make a choice, *e.g.*, to

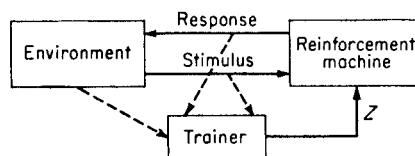

Figure 8. Parts of an "operant reinforcement" learning system. In response to a stimulus from the environment, the machine makes one of several possible responses. It remembers what decisions were made in choosing this response. Shortly thereafter, the Trainer sends to the machine positive or negative reinforcement (reward) signal; this increases or decreases the tendency to make the same decisions in the future. Note that the Trainer need not know how to solve problems, but only how to detect success or failure, or relative improvement; his function is selective. The Trainer might be connected to observe the actual stimulus-response activity, or, in a more interesting kind of system, just some function of the state of the environment.

turn left or right, and that its probability of turning right, at the n th trial, is p_n . Suppose that we want it to turn right. Whenever it does this we might "reward" it by applying the operator Z_+ ;

$$p_{n+1} = Z_+(p_n) = \theta p_n + (1 - \theta) \quad 0 < \theta < 1$$

which moves p a fraction $(1 - \theta)$ of the way toward unity.¹³ If we dislike what it does we apply negative reinforcement,

$$p_{n+1} = Z_-(p_n) = \theta p_n$$

moving p the same fraction of the way toward 0. Some theory of such "linear" learning operators, generalized to several stimuli and responses, will be found in Bush and Mosteller (1955). We can show that the learning result is an average weighted by an exponentially-decaying time factor: Let Z_n be ± 1 according to whether the n th event is rewarded or extinguished and replace p_n by $c_n = 2p_n - 1$ so that $-1 \leq c_n \leq 1$, as for a correlation coefficient. Then (with $c_0 = 0$) we obtain by induction

$$c_{n+1} = (1 - \theta) \sum_{i=0}^n \theta^{n-i} Z_i$$

and since

$$\frac{1}{1 - \theta} \approx \sum_0^n \theta^{n-i}$$

we can write this as

$$c_{n+1} \approx \frac{\sum \theta^{n-i} Z_i}{\sum \theta^{n-i}} \quad (1)$$

If the term Z_i is regarded as a product of (i) how the creature responded and (ii) which kind of reinforcement was given, then c_n is a kind of correlation function (with the decay weighting) of the joint behavior of these quantities. The ordinary, uniformly weighted average has the same general form but with time-dependent θ :

$$c_{n+1} = \left(1 - \frac{1}{N}\right) c_n + \frac{1}{N} Z_n \quad (2)$$

In (1) we have again the situation described in Sec. IIG1; a small value of θ gives fast learning, and the possibility of quick adaptation to a changing environment. A near-unity value of θ gives slow learning, but also smooths away uncertainties due to noise. As noted in Sec. IIG1, the response distribution comes to approximate the probabilities of rewards of the alternative responses. (The importance of this phenomenon has, I think, been overrated; it is certainly not an especially rational strategy. One reasonable alternative is that of computing the numbers p_{ij} as indi-

¹³ Properly, the reinforcement functions should depend both on the p 's and on the previous reaction—reward should decrease p if our animal has just turned to the left. The notation in the literature is also somewhat confusing in this regard.

cated, but actually playing at each trial the "most likely" choice. Except in the presence of a hostile opponent, there is usually no reason to play a "mixed" strategy.¹⁴)

In Samuel's coefficient-optimizing program (1959b) [see Sec. IIIC1], there is a most ingenious compromise between the exponential and the uniform averaging methods: the value of N in (2) above begins at 16 and so remains until $n = 16$, then N is 32 until $n = 32$, and so on until $n = 256$. Thereafter N remains fixed at 256. This nicely prevents violent fluctuations in c_n at the start, approaches the uniform weighting for a while, and finally approaches the exponentially weighted correlation, all in a manner that requires very little computation effort! Samuel's program is at present the outstanding example of a game-playing program which matches average human ability, and its success (in real time) is attributed to a wealth of such elegancies, both in heuristics and in programming.

The problem of extinction or "unlearning" is especially critical for complex, hierarchical, learning. For, once a generalization about the past has been made, one is likely to build upon it. Thus, one may come to select certain properties as important and begin to use them in the characterization of experience, perhaps storing one's memories in terms of them. If later it is discovered that some other properties would serve better, then one must face the problem of translating, or abandoning, the records based on the older system. This may be a very high price to pay. One does not easily give up an old way of looking at things, if the better one demands much effort and experience to be useful. Thus the *training sequences* on which our machines will spend their infancies, so to speak, must be chosen very shrewdly to insure that early abstractions will provide a good foundation for later difficult problems.

Incidentally, in spite of the space given here for their exposition, I am not convinced that such "incremental" or "statistical" learning schemes should play a central role in our models. They will certainly continue to appear as components of our programs but, I think, mainly by default. The more intelligent one is, the more often he should be able to learn from an experience something rather definite; *e.g.*, to reject or accept a hypothesis, or to change a goal. (The obvious exception is that of a truly statistical environment in which averaging is inescapable. But the heart of problem-solving is always, we think, the combinatorial part that gives rise to searches, and we should usually be able to regard the complexities caused by "noise" as mere annoyances, however irritating they may be.) In this connection we can refer to the discussion of memory in Miller, Galanter and Pribram (1960).¹⁵ This seems to be the first major work

¹⁴ The question of just how often one should play a strategy different from the estimated optimum, in order to gain information, is an underlying problem in many fields. See, *e.g.*, Shubik (1960).

¹⁵ See especially chap. 10.

in psychology to show the influence of work in the artificial intelligence area, and its programme is generally quite sophisticated.

B. Secondary Reinforcement and Expectation Models

The simple reinforcement system is limited by its dependence on the Trainer. If the Trainer can detect only the *solution* of a problem, then we may encounter "mesa" phenomena which will limit performance on difficult problems. (See Sec. IC.) One way to escape this is to have the machine learn to generalize on what the Trainer does. Then, in difficult problems, it may be able to give itself partial reinforcements along the way, *e.g.*, upon the solution of relevant subproblems. The machine in Fig. 9 has some such ability. The new unit U is a device that learns which external stimuli are strongly correlated with the various reinforcement signals, and responds to such stimuli by reproducing the corresponding reinforcement signals. (The device U is *not* itself a reinforcement learning device; it is more like a "Pavlovian" conditioning device, treating the Z signals as "unconditioned" stimuli and the S signals as conditioned stimuli.) The heuristic idea is that any signal from the environment which in the past has been well correlated with (say) positive reinforcement is likely to be an indication that something good has just happened. If the training on early problems was such that this is realistic, then the system eventually should be able to detach itself from the Trainer, and become autonomous. If we further permit "chaining" of the "secondary reinforcers," *e.g.*, by admitting the connection shown as a dotted line in Fig. 9, the scheme becomes quite powerful, in principle. There are obvious pitfalls in admitting

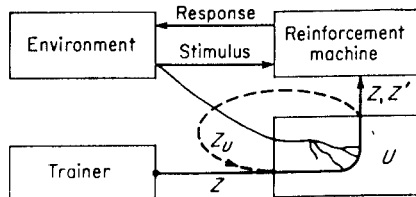

Figure 9. An additional device U gives the machine of Fig. 8 the ability to learn which signals from the environment have been associated with reinforcement. The primary reinforcement signals Z are routed through U . By a Pavlovian conditioning process (not described here), external signals come to produce reinforcement signals like those that have frequently succeeded them in the past. Such signals might be abstract, *e.g.*, verbal encouragement. If the "secondary reinforcement" signals are allowed, in turn, to acquire further external associations (through, *e.g.*, a channel Z_U as shown) the machine might come to be able to handle chains of subproblems. But something must be done to stabilize the system against the positive symbolic feedback loop formed by the path Z_U . The profound difficulty presented by this stabilization problem may be reflected in the fact that, in lower animals, it is very difficult to demonstrate such chaining effects.

such a degree of autonomy; the values of the system may drift to a "non-adaptive" condition.

C. Prediction and Expectation

The evaluation unit U is supposed to acquire an ability to tell whether a situation is good or bad. This evaluation could be applied to *imaginary* situations as well as to real ones. If we could estimate the consequences of a proposed action (without its actual execution), we could use U to evaluate the (estimated) resulting situation. This could help in reducing the effort in search, and we would have in effect a machine with some ability to look ahead, or *plan*. In order to do this we need an additional device P which, given the description of a situation and an action, will predict a description of the likely result. (We will discuss schemes for doing this in Sec. IVC.) The device P might be constructed along the lines of a reinforcement learning device. In such a system the required reinforcement signals would have a very attractive character. For the machine must reinforce P positively when the *actual outcome resembles that which was predicted*—accurate expectations are rewarded. If we could further add a premium to reinforcement of those predictions which have a novel aspect, we might expect to discern behavior motivated by a sort of curiosity. In the reinforcement of mechanisms for confirmed novel expectations (or new explanations) we may find the key to simulation of intellectual motivation.¹⁶

SAMUEL'S PROGRAM FOR CHECKERS

In Samuel's "generalization learning" program for the game of checkers (1959a) we find a novel heuristic technique which could be regarded as a simple example of the "expectation reinforcement" notion. Let us review very briefly the situation in playing two-person board games of this kind. As noted by Shannon (1956) such games are in principle finite, and a best strategy can be found by following out all possible continuations—if he goes there I can go there, or there, etc.—and then "backing up" or "minimaxing" from the terminal positions, won, lost, or drawn. But in practice the full exploration of the resulting colossal "move tree" is out of the question. No doubt, some exploration will always be necessary for such games. But the tree must be pruned. We might simply put a limit on depth of exploration—the number of moves and replies. We might also limit the number of alternatives explored from each position—this requires some heuristics for selection of "plausible moves."¹⁷ Now, if the backing-up technique is still to be used (with the incomplete move tree) one has to

¹⁶ See also chap. 6 of Minsky (1954).

¹⁷ See the discussion of Bernstein (1958) and the more extensive review and discussion in the very suggestive paper of Newell, Shaw and Simon (1958b).

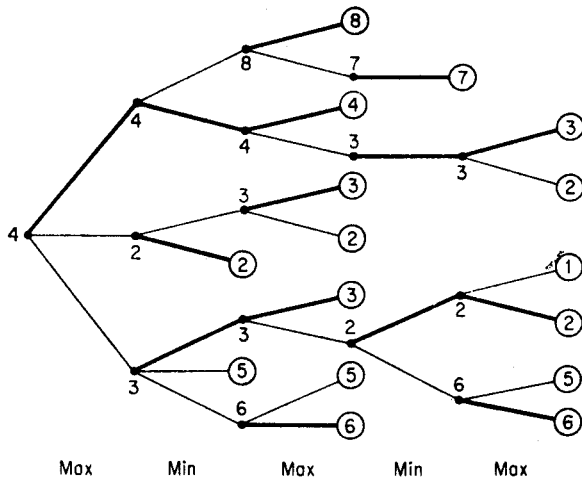

Figure 10. "Backing up" the static evaluations of proposed moves in a game tree. From the vertex at the left, representing the present position in a board game, radiate three branches, representing the *player's* proposed moves. Each of these might be countered by a variety of *opponent* moves, and so on. According to some program, a finite tree is generated. Then the worth to the player of each terminal board position is estimated (see text). If the opponent has the same values, he will choose to minimize the score, while the player will always try to maximize. The heavy lines show how this minimaxing process backs up until a choice is determined for the present position.

The full tree for chess has the order of 10^{120} branches—beyond the reach of any man or computer. There is a fundamental heuristic exchange between the effectiveness of the evaluation function and the extent of the tree. A very weak evaluation (e.g., one which just compares the players' values of pieces) would yield a devastating game if the machine could explore all continuations out to, say, 20 levels. But only 6 levels, roughly within the range of our presently largest computers, would probably not give a brilliant game; less exhaustive strategies, perhaps along the lines of Newell, Shaw, and Simon (1958b), would be more profitable.

substitute for the absolute "win, lose, or draw" criterion some other "static" way of evaluating nonterminal positions.¹⁸ (See Fig. 10.) Perhaps the simplest scheme is to use a weighted sum of some selected set of "property" functions of the positions—mobility, advancement, center control, and the like. This is done in Samuel's program, and in most of its predecessors. Associated with this is a multiple-simultaneous-optimizer method for discovering a good coefficient assignment (using the correlation technique noted in Sec. IIIA). But the source of reinforcement signals in

¹⁸ In some problems the backing-up process can be handled in closed analytic form so that one may be able to use such methods as Bellman's "Dynamic Programming" (1957). Freimer (1960) gives some examples for which limited "look-ahead" doesn't work.

Samuel (1959a) is novel. One cannot afford to play out one or more entire games for each single learning step. Samuel measures instead *for each move* the difference between what the evaluation function yields *directly* of a position and what it *predicts* on the basis of an extensive continuation exploration, *i.e.*, backing up. The sign of this error, "Delta," is used for reinforcement; thus the system may learn something at *each move*.¹⁹

D. The Basic Credit-assignment Problem for Complex Reinforcement Learning Systems

In playing a complex game such as chess or checkers, or in writing a computer program, one has a definite success criterion—the game is won or lost. But in the course of play, each ultimate success (or failure) is associated with a vast number of internal decisions. If the run is successful, how can we assign credit for the success among the multitude of decisions? As Newell noted,

*It is extremely doubtful whether there is enough information in "win, lose, or draw" when referred to the whole play of the game to permit any learning at all over available time scales. . . . For learning to take place, each play of the game must yield much more information. This is . . . achieved by breaking the problem into components. The unit of success is the goal. If a goal is achieved, its subgoals are reinforced; if not they are inhibited. (Actually, what is reinforced is the transformation rule that provided the subgoal.) . . . This also is true of the other kinds of structure: every tactic that is created provides information about the success or failure of tactic search rules; every opponent's action provides information about success or failure of likelihood inferences; and so on. The amount of information relevant to learning increases directly with the number of mechanisms in the chess-playing machine.*²⁰

We are in complete agreement with Newell on this approach to the problem.²¹

It is my impression that many workers in the area of "self-organizing" systems and "random neural nets" do not feel the urgency of this prob-

¹⁹ It should be noted that Samuel (1959a) describes also a rather successful checker-playing program based on recording and retrieving information about positions encountered in the past, a less abstract way of exploiting past experience. Samuel's work is notable in the variety of experiments that were performed, with and without various heuristics. This gives an unusual opportunity to really find out how different heuristic methods compare. More workers should choose (other things being equal) problems for which such variations are practicable.

²⁰ See p. 108 of Newell (1955).

²¹ See also the discussion in Samuel (p. 22, 1959a) on assigning credit for a change in "Delta."

lem. Suppose that one million decisions are involved in a complex task (such as winning a chess game). Could we assign to each decision element one-millionth of the credit for the completed task? In certain special situations we can do just this—*e.g.*, in the machines of Rosenblatt (1958), Roberts (1960), and Farley and Clark (1954), etc., where the connections being reinforced are to a sufficient degree independent. But the problem-solving ability is correspondingly weak.

For more complex problems, with decisions in hierarchies (rather than summed on the same level) and with increments small enough to assure probable convergence, the running times would become fantastic. For complex problems we will have to define "success" in some rich local sense. Some of the difficulty may be evaded by using carefully graded "training sequences" as described in the following section.

FRIEDBERG'S PROGRAM-WRITING PROGRAM

An important example of comparative failure in this credit-assignment matter is provided by the program of Friedberg (1958, 1959) to solve program-writing problems. The problem here is to write programs for a (simulated) very simple digital computer. A simple problem is assigned, *e.g.*, "compute the AND of two bits in storage and put the result in an assigned location." A generating device produces a random (64-instruction) program. The program is run and its success or failure is noted. The success information is used to reinforce *individual instructions* (in fixed locations) so that each success tends to increase the chance that the instructions of successful programs will appear in later trials. (We lack space for details of how this is done.) Thus the program tries to find "good" instructions, more or less independently, for each location in program memory. The machine did learn to solve some extremely simple problems. But it took of the order of 1000 times longer than pure chance would expect. In part II of Friedberg *et al.* (1959), this failure is discussed, and attributed in part to what we called (Sec. IC) the "Mesa phenomena." In changing just one instruction at a time the machine had not taken large enough steps in its search through program space.

The second paper goes on to discuss a sequence of modifications in the program generator and its reinforcement operators. With these, and with some "priming" (starting the machine off on the right track with some useful instructions), the system came to be only a little worse than chance. Friedberg *et al.* (1959) conclude that with these improvements "the generally superior performance of those machines with a success-number reinforcement mechanism over those without does serve to indicate that such a mechanism can provide a basis for constructing a learning machine." I disagree with this conclusion. It seems to me that each of the "improvements" can be interpreted as serving only to increase the step

size of the search, that is, the randomness of the mechanism; this helps to avoid the Mesa phenomenon and thus approach chance behavior. But it certainly does not show that the "learning mechanism" is working—one would want at least to see some better-than-chance results before arguing this point. The trouble, it seems, is with credit-assignment. The credit for a working program can only be assigned to functional groups of instructions, *e.g.*, subroutines, and as these operate in hierarchies we should not expect individual instruction reinforcement to work well.²² It seems surprising that it was not recognized in Friedberg *et al.* (1959) that the doubts raised earlier were probably justified! In the last section of Friedberg *et al.* (1959) we see some real success obtained by breaking the problem into parts and solving them sequentially. (This successful demonstration using division into subproblems does not use any reinforcement mechanism at all.) Some experiments of similar nature are reported in Kilburn, Grimdsdale and Sumner (1959).

It is my conviction that no scheme for learning, or for pattern recognition, can have very general utility unless there are provisions for recursive, or at least hierarchical, use of previous results. We cannot expect a learning system to come to handle very hard problems without preparing it with a reasonably graded sequence of problems of growing difficulty. The first problem must be one which can be solved in reasonable time with the initial resources. The next must be capable of solution in reasonable time by using reasonably simple and accessible combinations of methods developed in the first, and so on. The only alternatives to this use of an adequate "training sequence" are (1) advanced resources, given initially, or (2) the fantastic exploratory processes found perhaps only in the history of organic evolution.²³ And even there, if we accept the general view of Darlington (1958) who emphasizes the heuristic aspects of genetic systems, we must have developed early (in, *e.g.*, the phenomena of meiosis and crossing-over) quite highly specialized mechanisms providing for the segregation of groupings related to solutions of subproblems. Recently, much effort has been devoted to the construction of training sequences in connection with programming "teaching machines." Naturally, the psychological literature abounds with theories of how complex behavior is built

²² See the introduction to Friedberg (1958) for a thoughtful discussion of the plausibility of the scheme.

²³ It should, however, be possible to construct learning mechanisms which can select for themselves reasonably good training sequences (from an always complex environment) by prearranging a relatively slow development (or "maturation") of the system's facilities. This might be done by prearranging that sequence of goals attempted by the primary Trainer match reasonably well, at each stage, the complexity of performance mechanically available to the pattern-recognition and other parts of the system. One might be able to do much of this by simply limiting the depth of hierarchical activity, perhaps only later permitting limited recursive activity.

up from simpler. In our own area, perhaps the work of Solomonoff (1957), while overly cryptic, shows the most thorough consideration of this dependency on *training sequences*.

IV. Problem-solving and Planning

The solution, by machine, of really complex problems will require a variety of administration facilities. During the course of solving a problem, one becomes involved with a large assembly of interrelated subproblems. From these, at each stage, a very few must be chosen for investigation. This decision must be based on (1) estimates of relative difficulties and (2) estimates of centrality of the different candidates for attention. Following subproblem selection (for which several heuristic methods are proposed), one must choose methods appropriate to the selected problems. But for really difficult problems, even these step-by-step heuristics for reducing search will fail, and the machine must have resources for analyzing the problem structure in the large—in short, for “planning.” A number of schemes for planning are discussed, among them the use of models—analogue, semantic, and abstract. Certain abstract models, “Character-Algebras,” can be constructed by the machine itself, on the basis of experience or analysis. For concreteness, the discussion begins with a description of a simple but significant system (LT) which encounters some of these problems.

A. The “Logic Theory” Program of Newell, Shaw and Simon

It is not surprising that the testing grounds for early work on mechanical problem-solving have usually been areas of mathematics, or games, in which the rules are defined with absolute clarity. The “Logic Theory” machine of Newell and Simon (1956a, 1957a), called “LT” below, was a first attempt to prove theorems in logic, by frankly heuristic methods. Although the program was not by human standards a brilliant success (and did not surpass its designers), it stands as a landmark both in heuristic programming and also in the development of modern automatic programming.

The problem domain here is that of discovering proofs in the Russell-Whitehead system for the propositional calculus. That system is given as a set of (five) axioms and (three) rules of inference; the latter specify how certain transformations can be applied to produce new theorems from old theorems and axioms.

The LT program is centered around the idea of “working backward” to find a proof. Given a theorem T to be proved, LT searches among the axioms and previously established theorems for one from which T can be deduced by a single application of one of three simple “Methods” (which

embody the given rules of inference). If one is found, the problem is solved. Or the search might fail completely. But finally, the search may yield one or more "problems" which are usually propositions from which T may be deduced directly. If one of these can, in turn, be proved a theorem the main problem will be solved. (The situation is actually slightly more complex.) Each such subproblem is adjoined to the "subproblem list" (after a limited preliminary attempt) and LT works around to it later. The full power of LT, such as it is, can be applied to each subproblem, for LT can use itself as a subroutine in a recursive fashion.

The heuristic technique of working backward yields something of a teleological process, and LT is a forerunner of more complex systems which construct hierarchies of goals and subgoals. Even so, the basic administrative structure of the program is no more than a nested set of searches through lists in memory. We shall first outline this structure and then mention a few heuristics that were used in attempts to improve performance.

1. Take the next problem from problem list.
(If there are no more problems, EXIT with total failure.)
2. Choose the next of the three basic Methods.
(If no more methods, go to 1.)
3. Choose the next member of the list of axioms and previous theorems.
(If no more, go to 2.)
Then apply the Method to the problem, using the chosen theorem or axiom.
If problem is solved, EXIT with complete proof.
If no result, go to 3.
If new subproblem arises, go to 4.
4. Try the special (substitution) Method on the subproblem.
If problem is solved, EXIT with complete proof.
If no result, put the subproblem *at the end* of the problem list and go to 3.

Among the heuristics that were studied were (1) a *similarity test* to reduce the work in step 4 (which includes another search through the theorem list), (2) a *simplicity test* to select apparently easier problems from the problem list, and (3) a *strong nonprovability test* to remove from the problem list expressions which are probably false and hence not provable. In a series of experiments "learning" was used to find which earlier theorems had been most useful and should be given priority in step 3. We cannot review the effects of these changes in detail. Of interest was the balance between the extra cost for administration of certain heuristics and the resultant search reduction; this balance was quite delicate in some cases when computer memory became saturated. The system seemed to be

quite sensitive to the training sequence—the order in which problems were given. And some heuristics which gave no significant over-all improvement did nevertheless affect the class of solvable problems. Curiously enough, the general efficiency of LT was not greatly improved by any or all of these devices. But all this practical experience is reflected in the design of the much more sophisticated “GPS” system described briefly in Sec. IVD2.

Wang (1960) has criticized the LT project on the grounds that there exist, as he and others have shown, mechanized proof methods which, for the particular run of problems considered, use far less machine effort than does LT and which have the advantage that they will ultimately find a proof for any provable proposition. (LT does not have this exhaustive “decision procedure” character and can fail ever to find proofs for some theorems.) The authors of “Empirical Explorations of the Logic Theory Machine,” perhaps unaware of the existence of even moderately efficient exhaustive methods, supported their arguments by comparison with a particularly inefficient exhaustive procedure. Nevertheless, I feel that some of Wang’s criticisms are misdirected. He does not seem to recognize that the authors of LT are not so much interested in proving these theorems as they are in the general problem of solving difficult problems. The combinatorial system of Russell and Whitehead (with which LT deals) is far less simple and elegant than the system used by Wang.²⁴ [Note, *e.g.*, the emphasis in Newell, Shaw and Simon (1958*a*, 1958*b*).] Wang’s problems, while *logically* equivalent, are *formally* much simpler. His methods do not include any facilities for using previous results (hence they are sure to degrade rapidly at a certain level of problem complexity), while LT is fundamentally oriented around this problem. Finally, because of the very effectiveness of Wang’s method on the *particular* set of theorems in question, he simply did not have to face the fundamental heuristic problem of *when to decide to give up on a line of attack*. Thus the formidable performance of his program (1960) perhaps diverted his attention from heuristic problems that must again spring up when real mathematics is ultimately encountered.

This is not meant as a rejection of the importance of Wang’s work and discussion. He and others working on “mechanical mathematics” have discovered that there are proof procedures which are much more efficient than has been suspected. Such work will unquestionably help in constructing intelligent machines, and these procedures will certainly be preferred, when available, to “unreliable heuristic methods.” Wang, Davis and

²⁴ Wang’s procedure (1960*a*), too, works backward, and can be regarded as a generalization of the method of “falsification” for deciding truth-functional tautology. In Wang (1960*b*) and its unpublished sequel, he introduces more powerful methods (for much more difficult problems).

Putnam, and several others are now pushing these new techniques into the far more challenging domain of theorem proving in the predicate calculus (for which exhaustive decision procedures are no longer available). We have no space to discuss this area,²⁵ but it seems clear that a program to solve real mathematical problems will have to combine the mathematical sophistication of Wang with the heuristic sophistication of Newell, Shaw and Simon.²⁶

B. Heuristics for Subproblem Selection

In designing a problem-solving system, the programmer often comes equipped with a set of more or less distinct "Methods"—his real task is to find an efficient way for the program to decide where and when the different methods are to be used.

Methods which do not dispose of a problem may still transform it to create new problems or subproblems. Hence, during the course of solving one problem we may become involved with a large assembly of interrelated subproblems. A "parallel" computer, yet to be conceived, might work on many at a time. But even the parallel machine must have procedures to allocate its resources because it cannot simultaneously apply all its methods to all the problems. We shall divide this administrative problem into two parts: the selection of those subproblem(s) which seem most critical, attractive, or otherwise immediate, and, in the next section, the choice of which method to apply to the selected problem.

In the basic program for LT (Sec. IV A), subproblem selection is very simple. New problems are examined briefly and (if not solved at once) are placed at the end of the (linear) problem list. The main program proceeds along this list (step 1), attacking the problems in the order of their generation. More powerful systems will have to be more judicious (both in generation and selection of problems) for only thus can excessive branching be restrained.²⁷ In more complex systems we can expect to consider for each subproblem, at least these two aspects: (1) its apparent "centrality"—how will its solution promote the main goal, and (2) its apparent "difficulty"—how much effort is it liable to consume. We need heuristic methods to estimate each of these quantities and, further, to

²⁵ See Davis and Putnam (1960), and Wang (1960b).

²⁶ All these efforts are directed toward the reduction of search effort. In that sense they are all heuristic programs. Since practically no one still uses "heuristic" in a sense opposed to "algorithmic," serious workers might do well to avoid pointless argument on this score. The real problem is to find methods which significantly delay the apparently inevitable exponential growth of search trees.

²⁷ Note that the simple scheme of LT has the property that each generated problem will eventually get attention, even if several are created in a step 3. If one were to turn *full* attention to each problem, as generated, one might never return to alternate branches.

select accordingly one of the problems and allocate to it some reasonable quantity of effort.²⁸ Little enough is known about these matters, and so it is not entirely for lack of space that the following remarks are somewhat cryptic.

Imagine that the problems and their relations are arranged to form some kind of directed-graph structure (Minsky, 1956*b*; Newell and Simon, 1956*b*; Gelernter and Rochester, 1958). The main problem is to establish a "valid" path between two initially distinguished nodes. Generation of new problems is represented by the addition of new, not-yet-valid paths, or by the insertion of new nodes in old paths. Then problems are represented by not-yet-valid paths, and "centrality" by location in the structure. Associate with each connection, quantities describing its current validity state (solved, plausible, doubtful, etc.) and its current estimated difficulty.

1. GLOBAL METHODS

The most general problem-selection methods are "global"—at each step they look over the entire structure. There is one such simple scheme which works well on at least one rather degenerate interpretation of our problem graph. This is based on an electrical analogy suggested to us by a machine designed by Shannon [related to one described in Shannon (1955) which describes quite a variety of interesting game-playing and learning machines] to play a variant of the game marketed as "Hex" (and known among mathematicians as "Nash"). The initial board position can be represented as a certain network of resistors. (See Fig. 11.) One player's goal is to construct a *short-circuit* path between two given boundaries; the opponent tries to open the circuit between them. Each move consists of shorting (or opening), irreversibly, one of the remaining resistors. Shannon's machine applies a potential between the boundaries and selects that resistor which carries the largest current. Very roughly speaking, this resistor is likely to be most critical because changing it will have the largest effect on the resistance of the net and, hence, in the goal direction of shorting (or opening) the circuit. And although this argument is not perfect, nor is this a perfect model of the real combinatorial situation, the machine does play extremely well. (It can make unsound moves in certain artificial situations, but no one seems to have been able to force this during a game.)

The use of such a global method for problem selection requires that the available "difficulty estimates" for related subproblems be arranged to

²⁸ One will want to see if the considered problem is the same as one already considered, or very similar. See the discussion in Gelernter and Rochester (1958). This problem might be handled more generally by simply *remembering* the (Characters of) problems that have been attacked, and checking new ones against this memory, e.g., by methods of Mooers (1956), looking more closely if there seems to be a match.

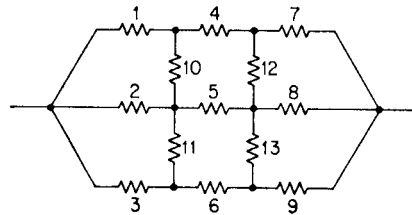

Figure 11. This board game (due to C. E. Shannon) is played on a network of equal resistors. The first player's goal is to open the circuit between the end points; the second player's goal is to short the circuit. A move consists of opening or shortening a resistor. If the first player begins by opening resistor 1, the second player might counter by shorting resistor 4, following the strategy described in the text. The remaining move pairs (if *both* players use that strategy) would be (5, 8) (9, 13) (12, 10 or 2) (2 or 10 *win*). In this game the first player should be able to force a win, and the maximum-current strategy seems always to do so, even on larger networks.

combine in roughly the manner of resistance values. Also, we could regard this machine as using an "analog model" for "planning." (See Sec. IVD.)²⁹

2. LOCAL, AND "HEREDITARY," METHODS

The prospect of having to study at each step the whole problem structure is discouraging, especially since the structure usually changes only slightly after each attempt. One naturally looks for methods which merely *update* or modify a small fragment of the stored record. Between the extremes of the "first-come-first-served" problem-list method and the full global-survey methods, lie a variety of compromise techniques. Perhaps the most attractive of these are what we will call the *Inheritance* methods—essentially recursive devices.

In an Inheritance method, the effort assigned to a subproblem is determined only by its immediate ancestry; at the time each problem is created it is assigned a certain total quantity Q of time or effort. When a problem is later split into subproblems, such quantities are assigned to them by some local process which *depends only on their relative merits and on what remains of Q* . Thus the centrality problem is managed implicitly. Such schemes are quite easy to program, especially with the new programming systems such as IPL (Newell and Tonge, 1960c) and LISP (McCarthy, 1960) (which are themselves based on certain hereditary or recursive operations). Special cases of the Inheritance method arise when one can get along with a simple all-or-none Q , *e.g.*, a "stop condition"—this yields the

²⁹ A variety of combinatorial methods will be matched against the network-analogy opponent in a program being completed by R. Silver, Lincoln Laboratory, MIT, Lexington, Mass.

exploratory method called "backtracking" by Golumb (1961). The decoding procedure of Wozencraft (1961) is another important variety of Inheritance method.

In the complex exploration process proposed for chess by Newell, Shaw, and Simon (1958*b*) we have a form of Inheritance method with a *non-numerical stop condition*. Here, the subproblems inherit *sets of goals to be achieved*. This teleological control has to be administered by an additional goal-selection system and is further complicated by a global (but reasonably simple) stop rule of the back-up variety (Sec. IIC). (*Note*: we are identifying here the move-tree-limitation problem with that of problem selection.) Even though extensive experimental results are not yet available, we feel that the scheme of Newell, Shaw, and Simon (1958*b*) deserves careful study by anyone planning serious work in this area. It shows only the beginning of the complexity sure to come in our development of intelligent machines.³⁰

C. "Character-Method" Machines

Once a problem is selected, we must decide which method to try first. This depends on our ability to classify or characterize problems. We first compute the Character of our problem (by using some pattern recognition technique) and then consult a "Character-Method" table or other device which is supposed to tell us which method(s) are most effective on problems of that Character. This information might be built up from experience, given initially by the programmer, deduced from "advice" (McCarthy, 1959), or obtained as the solution to some other problem, as suggested in the GPS proposal (Newell, Shaw and Simon, 1959*a*). In any case, this part of the machine's behavior, regarded from the outside, can be treated as a sort of stimulus-response, or "table look-up," activity.

If the Characters (or descriptions) have too wide a variety of values, there will be a serious problem of filling a Character-Method table. One might then have to reduce the detail of information, *e.g.*, by using only a few important properties. Thus the *Differences* of GPS (see Sec. IVD2) describe no more than is necessary to define a single goal, and a priority scheme selects just one of these to characterize the situation. Gelernter and Rochester (1958) suggest using a property-weighting scheme, a special case of the "Bayes net" described in Sec. IIG.

D. Planning

Ordinarily one can solve a complicated problem only by dividing it into a number of parts, each of which can be attacked by a smaller search (or be further divided). Generally speaking, a successful division will reduce

³⁰ Some further discussion of this question may be found in Slagle (1961).

the search time not by a mere fraction, but by a *fractional exponent*. In a graph with 10 branches descending from each node, a 20-step search might involve 10^{20} trials, which is out of the question, while the insertion of just four *lemmas* or *sequential subgoals* might reduce the search to only 5×10^4 trials, which is within reason for machine exploration. Thus it will be worth a relatively enormous effort to find such "islands" in the solution of complex problems.³¹ Note that even if one encountered, say, 10^6 failures of such procedures before success, one would still have gained a factor of perhaps 10^{10} in over-all trial reduction! *Thus practically any ability at all to "plan," or "analyze," a problem will be profitable*, if the problem is difficult. It is safe to say that all simple, unitary, notions of how to build an intelligent machine will fail, rather sharply, for some modest level of problem difficulty. Only schemes which actively pursue an analysis toward obtaining a set of *sequential goals* can be expected to extend smoothly into increasingly complex problem domains.

Perhaps the most straightforward concept of planning is that of using a *simplified model* of the problem situation. Suppose that there is available, for a given problem, some other problem of "essentially the same character" but with less detail and complexity. Then we could proceed first to solve the simpler problem. Suppose, also, that this is done using a second set of methods, which are also simpler, but in some correspondence with those for the original. *The solution to the simpler problem can then be used as a "plan" for the harder one*. Perhaps each step will have to be expanded in detail. But the multiple searches will *add, not multiply*, in the total search time. The situation would be ideal if the model were, mathematically, a *homomorphism* of the original. But even without such perfection the model solution should be a valuable guide. In mathematics one's proof procedures usually run along these lines: one first assumes, *e.g.*, that integrals and limits always converge, in the planning stage. Once the outline is completed, in this simpleminded model of mathematics, then one goes back to try to "make rigorous" the steps of the proof, *i.e.*, to replace them by chains of argument using genuine rules of inference. And even if the plan fails, it may be possible to patch it by replacing just a few of its steps.

Another aid to planning is the *semantic*, as opposed to the homomorphic, model (Minsky, 1956a, 1959a). Here we may have an *interpretation* of the current problem within another system, not necessarily simpler, but with which we are more familiar and have already more powerful methods. Thus, in connection with a plan for the proof of a theorem, we will want to know whether the proposed lemmas, or islands in the proof, are actually *true*; if not, the plan will surely fail. We can often easily tell if a proposition is true by looking at an interpretation. Thus the truth of a

³¹ See sec. 10 of Ashby (1956).

proposition from plane geometry can be supposed, at least with great reliability, by actual measurement of a few constructed drawings (or the analytic geometry equivalent). The geometry machine of Gelernter and Rochester (1958, 1959) uses such a semantic model with excellent results; it follows closely the lines proposed in Minsky (1956a).

1. THE "CHARACTER-ALGEBRA" MODEL

Planning with the aid of a model is of the greatest value in reducing search. Can we construct machines which find their own models? I believe the following will provide a general, straightforward way to construct certain kinds of useful, abstract models. The critical requirement is that we be able to compile a "Character-Method Matrix" (in addition to the simple Character-Method table in Sec. IVC). *The CM matrix is an array of entries which predict with some reliability what will happen when methods are applied to problems.* Both of the matrix dimensions are indexed by problem Characters; if there is a method which usually transforms problems of character C_i into problems of character C_j then let the matrix entry C_{ij} be the name of that method (or a list of such methods). If there is no such method the corresponding entry is null.

Now suppose that there is no entry for C_{ij} —meaning that we have no direct way to transform a problem of type C_i into one of type C_j . Multiply the matrix by itself. If the new matrix has a non-null (i,j) entry then there must be a sequence of two methods which effects the desired transformation. If that fails, we may try higher powers. Note that [if we put unity for the (i,i) terms] we can reach the 2^n matrix power with just n multiplications. We don't need to define the symbolic multiplication operation; one may instead use arithmetic entries—putting unity for any non-null entry and zero for any null entry in the original matrix. This yields a simple connection, or flow diagram, matrix, and its n th power tells us something about its set of paths of length 2^n .³² [Once a non-null entry is discovered, there exist efficient ways to find the corresponding sequences of methods. The problem is really just that of finding paths through a maze, and the method of Moore (1959) would be quite efficient. Almost any problem can be converted into a problem of finding a chain between two terminal expressions in some formal system.] If the Characters are taken to be abstract representations of the problem expressions, this "Character-Algebra" model can be as abstract as are the available pattern-recognition facilities. See Minsky (1956a, 1959a).

The critical problem in using the Character-Algebra model for planning is, of course, the *prediction reliability of the matrix entries*. One cannot expect the Character of a result to be strictly determined by the Character of the original and the method used. And the reliability of the pre-

³² See, e.g., Hohn, Seshu, and Aufenkamp (1957).

dictions will, in any case, deteriorate rapidly as the matrix power is raised. But, as we have noted, any plan at all is so much better than none that the system should do very much better than exhaustive search, even with quite poor prediction quality.

This matrix formulation is obviously only a special case of the character planning idea. More generally, one will have descriptions, rather than fixed characters, and one must then have more general methods to calculate from a description what is likely to happen when a method is applied.

2. CHARACTERS AND DIFFERENCES

In the GPS (General Problem Solver) proposal of Newell, Shaw, and Simon (1959a, 1960a) we find a slightly different framework: they use a notion of Difference between two problems (or expressions) where we speak of the Character of a single problem. These views are equivalent if we take our problems to be links or connections between expressions. But this notion of Difference (as the Character of a pair) does lend itself more smoothly to teleological reasoning. For what is the goal defined by a problem but to *reduce the "difference" between the present state and the desired state?* The underlying structure of GPS is precisely what we have called a "Character-Method Machine" in which each kind of Difference is associated in a table with one or more methods which are known to "reduce" that Difference. Since the characterization here depends always on (1) the current problem expression and (2) the desired end result, it is reasonable to think, as its authors suggest, of GPS as using "means-end" analysis.

To illustrate the use of Differences, we shall review an example (Newell, Shaw, and Simon, 1960a). The problem, in elementary propositional calculus, is to prove that from $S \wedge (-P \supset Q)$ we can deduce $(Q \vee P) \wedge S$. The program looks at both of these expressions with a recursive *matching* process which branches out from the main connectives. The first Difference it encounters is that S occurs on different sides of the main connective " \wedge ." It therefore looks in the Difference-Method table under the heading "change position." It discovers there a method which uses the theorem $(A \wedge B) \equiv (B \wedge A)$ which is obviously useful for removing, or "reducing," differences of position. GPS applies this method, obtaining $(-P \supset Q) \wedge S$. GPS now asks what is the Difference between this new expression and the goal. This time the matching procedure gets down into the connectives inside the left-hand members and finds a Difference between the connectives " \supset " and " \vee ." It now looks in the CM table under the heading "Change Connective" and discovers the appropriate method using $(-A \supset B) \equiv (A \vee B)$. It applies this method, obtaining $(P \vee Q) \wedge S$. In the final cycle, the difference-evaluating procedure discovers the need for a "change position" inside the left member, and applies a

method using $(A \vee B) \equiv (B \vee A)$. This completes the solution of the problem.³³

Evidently, the success of this "means-end" analysis in reducing general search will depend on the degree of specificity that can be written into the Difference-Method table—basically the same requirement for an effective Character-Algebra.

It may be possible to *plan* using Differences, as well. One might imagine a "Difference-Algebra" in which the predictions have the form $D = D' D''$. One must construct accordingly a difference-factorization algebra for discovering longer chains $D = D_1 \cdot \cdot \cdot D_n$ and corresponding method plans. We should note that one *cannot* expect to use such planning methods with such primitive Differences as are discussed in Newell, Shaw, and Simon (1960a); for these cannot form an adequate Difference-Algebra (or Character-Algebra). Unless the characterizing expressions have many levels of descriptive detail, the matrix powers will too swiftly become degenerate. This degeneracy will ultimately limit the capacity of any formal planning device.

One may think of the general planning heuristic as embodied in a recursive process of the following form. Suppose we have a problem P :

1. Form a plan for problem P .
2. Select first (next) step of the plan.
(If no more steps, exit with "success.")
3. Try the suggested method(s):
Success: return to (b), *i.e.*, try next step in the plan.
Failure: return to (a), *i.e.*, form new plan, or perhaps change current plan to avoid this step.
Problem judged too difficult: *Apply this entire procedure to the problem of the current step.*

Observe that such a program schema is essentially recursive; it uses itself as a subroutine (explicitly, in the last step) in such a way that its current state has to be stored, and restored when it returns control to itself.³⁴

³³ Compare this with the "matching" process described in Newell and Simon (1956). The notions of "Character," "Character-Algebra," etc., originate in Minsky (1956) but seem useful in describing parts of the "GPS" system of Newell and Simon (1956) and Newell, Shaw, and Simon (1960a). The latter contains much additional material we cannot survey here. Essentially, GPS is to be self-applied to the problem of discovering sets of Differences appropriate for given problem areas. This notion of "bootstrapping"—applying a problem-solving system to the task of improving some of its own methods—is old and familiar, but in Newell, Shaw, and Simon (1960a) we find perhaps the first specific proposal about how such an advance might be realized.

³⁴ This violates, for example, the restrictions on "DO loops" in programming systems such as FORTRAN. Convenient techniques for programming such processes were developed by Newell, Shaw and Simon (1960b); the program state variables

Miller, Galanter and Pribram³⁵ discuss possible analogies between human problem-solving and some heuristic planning schemes. It seems certain that, for at least a few years, there will be a close association between theories of human behavior and attempts to increase the intellectual capacities of machines. But, in the long run, we must be prepared to discover profitable lines of heuristic programming which do not deliberately imitate human characteristics.³⁶

V. Induction and Models

A. Intelligence

In all of this discussion we have not come to grips with anything we can isolate as "intelligence." We have discussed only heuristics, shortcuts, and classification techniques. Is there something missing? I am confident that sooner or later we will be able to assemble programs of great problem-solving ability from complex combinations of heuristic devices—multiple optimizers, pattern-recognition tricks, planning algebras, recursive administration procedures, and the like. In no one of these will we find the

are stored in "pushdown lists" and both the program and the data are stored in the form of "list structures." Gelernter (1959) extended FORTRAN to manage some of this. McCarthy has extended these notions in LISP (1960) to permit *explicit* recursive definitions of programs in a language based on recursive functions of symbolic expressions; here the management of program state variables is fully automatic. See also Orchard-Hays (1960).

³⁵ See chaps. 12 and 13 of Miller, Galanter, and Pribram (1960).

³⁶ Limitations of space preclude detailed discussion here of theories of self-organizing neural nets, and other models based on brain analogies. [Several of these are described or cited in *Proceedings of a Symposium on Mechanisation of Thought Processes*, London: H. M. Stationery Office, 1959, and *Self Organizing Systems*, M. T. Yovitts and S. Cameron (eds.), New York: Pergamon Press, 1960.] This omission is not too serious, I feel, in connection with the subject of heuristic programming, because the motivation and methods of the two areas seem so different. Up to the present time, at least, research on neural-net models has been concerned mainly with the attempt to show that certain rather simple heuristic processes, e.g., reinforcement learning, or property-list pattern recognition, can be realized or evolved by collections of simple elements without very highly organized interconnections. Work on heuristic programming is characterized quite differently by the search for new, more powerful heuristics for solving very complex problems, and by very little concern for what hardware (neuronal or otherwise) would minimally suffice for its realization. In short, the work on "nets" is concerned with how far one can get with a small initial endowment; the work on "artificial intelligence" is concerned with using all we know to build the most powerful systems that we can. It is my expectation that, in problem-solving power, the (allegedly brainlike) minimal-structure systems will never threaten to compete with their more deliberately designed contemporaries; nevertheless, their study should prove profitable in the development of component elements and subsystems to be used in the construction of the more systematically conceived machines.

seat of intelligence. Should we ask what intelligence "really is"? My own view is that this is more of an aesthetic question, or one of sense of dignity, than a technical matter! To me "intelligence" seems to denote little more than the complex of performances which we happen to respect, but do not understand. So it is, usually, with the question of "depth" in mathematics. Once the proof of a theorem is really understood its content seems to become trivial. (Still, there may remain a sense of wonder about how the proof was discovered.)

Programmers, too, know that there is never any "heart" in a program. There are high-level routines in each program, but all they do is dictate that "if such and such, then transfer to such and such a subroutine." And when we look at the low-level subroutines, which "actually do the work," we find senseless loops and sequences of trivial operations, merely carrying out the dictates of their superiors. The intelligence in such a system seems to be as intangible as becomes the meaning of a single common word when it is thoughtfully pronounced over and over again.

But we should not let our inability to discern a locus of intelligence lead us to conclude that programmed computers therefore cannot think. For it may be so with *man*, as with *machine*, that, when we understand finally the structure and program, the feeling of mystery (and self-approbation) will weaken.³⁷ We find similar views concerning "creativity" in Newell, Shaw, and Simon (1958c). The view expressed by Rosenbloom (1951) that minds (or brains) can transcend machines is based, apparently, on an erroneous interpretation of the meaning of the "unsolvability theorems" of Godel.³⁸

³⁷ See Minsky (1956, 1959).

³⁸ On problems of volition we are in general agreement with McCulloch (1954) that our *freedom of will* "presumably means no more than that we can distinguish between what we intend (*i.e.*, our *plan*), and some intervention in our action." See also MacKay (1959) and [the] references; we are, however, unconvinced by his eulogization of "analog" devices. Concerning the "mind-brain" problem, one should consider the arguments of Craik (1952), Hayek (1952), and Pask (1959). Among the active leaders in modern heuristic programming, perhaps only Samuel (1960b) has taken a strong position against the idea of machines thinking. His argument, based on the fact that reliable computers do only that which they are instructed to do, has a basic flaw; it does not follow that the programmer therefore has full knowledge (and therefore full responsibility and credit for) what will ensue. For certainly the programmer may set up an evolutionary system whose limitations are for him unclear and possibly incomprehensible. No better does the mathematician know all the consequences of a proposed set of axioms. Surely a machine has to *be* in order to perform. But we cannot assign all the credit to its programmer if the operation of a system comes to reveal structures not recognizable or anticipated by the programmer. While we have not yet seen much in the way of intelligent activity in machines, Samuel's arguments (circular in that they are based on the presumption that machines do not have minds) do not assure us against this. Turing (1956) gives a very knowledgeable discussion of such matters.

B. Inductive Inference

Let us pose now for our machines, a variety of problems more challenging than any ordinary game or mathematical puzzle. Suppose that we want a machine which, when embedded for a time in a complex environment or "universe," will essay to produce a description of that world—to discover its regularities or laws of nature. We might ask it to predict what will happen next. We might ask it to predict what would be the likely consequences of a certain action or experiment. Or we might ask it to formulate the laws governing some class of events. In any case, our task is to equip our machine with *inductive ability*—with methods which it can use to construct general statements about events beyond its recorded experience. Now, there can be no system for inductive inference that will work well in all possible universes. But given a universe, or an ensemble of universes, and a criterion of success, this (epistemological) problem for machines becomes technical rather than philosophical. There is quite a literature concerning this subject, but we shall discuss only one approach which currently seems to us the most promising; this is what we might call the "grammatical induction" schemes of Solomonoff (1957, 1958, 1959a), based partly on work of Chomsky and Miller (1957b, 1958).

We will take *language* to mean the set of expressions formed from some given set of primitive symbols or expressions, by the repeated application of some given set of rules; the primitive expressions plus the rules is the *grammar* of the language. Most induction problems can be framed as problems in the *discovery of grammars*. Suppose, for instance, that a machine's prior experience is summarized by a large collection of statements, some labelled "good" and some "bad" by some critical device. How could we generate selectively more good statements? The trick is to find some relatively simple (formal) language in which the good statements are grammatical, and in which the bad ones are not. Given such a language, we can use it to generate more statements, and presumably these will tend to be more like the good ones. The heuristic argument is that if we can find a relatively simple way to separate the two sets, the discovered rule is likely to be useful beyond the immediate experience. If the extension fails to be consistent with new data, one might be able to make small changes in the rules and, generally, one may be able to use many ordinary problem-solving methods for this task.

The problem of finding an efficient grammar is much the same as that of finding efficient *encodings*, or programs, for machines; in each case, one needs to discover the important regularities in the data, and exploit the regularities by making shrewd *abbreviations*. The possible importance of Solomonoff's work (1960) is that, despite some obvious defects, it may

point the way toward systematic mathematical ways to explore this discovery problem. He considers the class of all programs (for a given general-purpose computer) which will produce a certain given output (the body of data in question). Most such programs, if allowed to continue, will add to that body of data. By properly weighting these programs, perhaps by length, we can obtain corresponding weights for the different possible continuations, and thus a basis for prediction. If this prediction is to be of any interest, it will be necessary to show some independence of the given computer; it is not yet clear precisely what form such a result will take.

C. Models of Oneself

If a creature can answer a question about a hypothetical experiment, without actually performing that experiment, then the answer must have been obtained from some submachine inside the creature. The output of that submachine (representing a correct answer) as well as the input (representing the question) must be coded descriptions of the corresponding external events or event classes. Seen through this pair of encoding and decoding channels, the internal submachine acts like the environment, and so it has the character of a "model." The inductive inference problem may then be regarded as the problem of constructing such a model.

To the extent that the creature's actions affect the environment, this internal model of the world will need to include some representation of the creature itself. If one asks the creature "why did you decide to do such and such" (or if it asks this of itself), any answer must come from the internal model. Thus the evidence of introspection itself is liable to be based ultimately on the processes used in constructing one's image of one's self. Speculation on the form of such a model leads to the amusing prediction that intelligent machines may be reluctant to believe that they are *just* machines. The argument is this: our own self-models have a substantially "dual" character; there is a part concerned with the physical or mechanical environment—with the behavior of inanimate objects—and there is a part concerned with social and psychological matters. It is precisely because we have not yet developed a satisfactory mechanical theory of mental activity that we have to keep these areas apart. We could not give up this division even if we wished to—until we find a unified model to replace it. Now, when we ask such a creature what sort of being it is, it cannot simply answer "directly"; it must inspect its model(s). And it must answer by saying that it seems to be a dual thing—which appears to have two parts—a "mind" and a "body." Thus, even the robot, unless equipped with a satisfactory theory of artificial intelligence, would have to maintain a dualistic opinion on this matter.³⁹

³⁹ There is a certain problem of infinite regression in the notion of a machine

Conclusion

In attempting to combine a survey of work on "artificial intelligence" with a summary of our own views, we could not mention every relevant project and publication. Some important omissions are in the area of "brain models"; the early work of Farley and Clark (1954) [also Farley's paper in Yovitts and Cameron (1960), often unknowingly duplicated, and the work of Rochester (1956) and Milner (1960)]. The work of Lettvin *et al.* (1959) is related to the theories in Selfridge (1959). We did not touch at all on the problems of logic and language, and of information retrieval, which must be faced when action is to be based on the contents of large memories; see, *e.g.*, McCarthy (1959). We have not discussed the basic results in mathematical logic which bear on the question of what can be done by machines. There are entire literatures we have hardly even sampled—the bold pioneering work of Rashevsky (c. 1929) and his later co-workers (Rashevsky, 1960); Theories of Learning, *e.g.*, Gorn (1959); Theory of Games, *e.g.*, Shubik (1960); and Psychology, *e.g.*, Bruner *et al.* (1956). And everyone should know the work of Polya (1945, 1954) on how to solve problems. We can hope only to have transmitted the flavor of some of the more ambitious projects *directly* concerned with getting machines to take over a larger portion of problem-solving tasks.

One last remark: we have discussed here only work concerned with more or less self-contained problem-solving programs. But as this is written, we are at last beginning to see vigorous activity in the direction of constructing usable *time-sharing* or *multiprogramming* computing systems. With these systems, it will at last become economical to match human beings in real time with really large machines. This means that we can work toward programming what will be, in effect, "thinking aids." In the years to come, we expect that these man-machine systems will share, and perhaps for a time be dominant, in our advance toward the development of "artificial intelligence."

having a *good* model of itself: of course, the nested models must lose detail and finally vanish. But the argument, *e.g.*, of Hayek (see 8.69 and 8.79, 1952) that we cannot "fully comprehend the unitary order" (of our own minds) ignores the power of recursive description as well as Turing's demonstration that (with sufficient external writing space) a "general-purpose" machine can answer any question about a description of itself that any larger machine could answer.