

Report 78-23
Stanford -- KSL

SACON: A Knowledge-Based Consultant
for Structural Analysis.
James S. Bennett, Lewis Creary, Robert S.

Scientific DataLink

Englewood Robert Melosh Sep 1978

card 1 of 1

Stanford Heuristic Programming Project
Memo HPP-78-23

September 1978

Computer Science Department
Report No. STAN-CS-78-699

SACON:
A KNOWLEDGE-BASED CONSULTANT FOR STRUCTURAL ANALYSIS

by

James Bennett, Lewis Creary, Robert Englemore and Robert Melosh

COMPUTER SCIENCE DEPARTMENT
School of Humanities and Sciences
STANFORD UNIVERSITY

HEURISTIC PROGRAMMING PROJECT

Computer Science Department

Stanford University

SACON: A KNOWLEDGE-BASED CONSULTANT FOR STRUCTURAL ANALYSIS

James Bennett, Lewis Creary, Robert Engelmores and Robert Melosh

Principal Investigators:

**Edward A. Feigenbaum
Joshua Lederberg
Bruce Buchanan**

This research was supported by the Defense Advanced Research Projects Agency under ARPA Order No. 2494 Contract No. DAHC15-73-C-0435. The views and conclusions contained in this document are those of the authors and should not be interpreted as necessarily representing the official policies, either express or implied, of the Defense Advanced Research Projects Agency or the United States Government.

September, 1978

Acknowledgements

We wish to acknowledge the Air Force Flight Dynamics Laboratory at Wright Patterson Air Force Base for making funds available to pursue the work reported here, and to thank Dr. Laszlo Berke of AFFDL for his advice and encouragement as monitor of this special project. We also wish to acknowledge the cooperation and advice of Dr. Pedro Marcal, president of MARC Analysis Research Corporation.

Mr. William van Melle and Ms. Carli Scott provided invaluable technical advice on the care, feeding and enjoyment of the EMYCIN system.

Table of Contents

Section	Subsection	Page
	Acknowledgements	II
1.	Introduction	1
	1.1 Motivation	1
	1.2 Knowledge-based systems	2
	1.3 Some examples of knowledge-based systems	2
	1.4 Scope of this report	3
2.	Computer consultants and the EMYCIN system	4
	2.1 A short example	5
	2.2 Knowledge base organization	8
	2.3 The inference engine.	11
3.	The Structural Mechanics Knowledge Base	13
	3.1 Analysis Strategies	13
	3.2 Material Behaviors	14
	3.3 Substructures	15
	3.4 Loadings	17
	3.5 Major Reasoning Steps	17
	3.6 The Mathematical Model	18

3.7	Summary	19
4.	Example Consultations	20
4.1	Analysis of an Airplane Wing.	20
4.2	Analysis of a Concrete Building	34
4.3	Conclusions	44
5.	Summary	45
5.1	What did we accomplish	45
5.2	Contributions to Artificial Intelligence	45
5.3	Extensions to SACON.	48
6.	Appendix 1: Parameter Definitions	50
6.1	Structure parameters.	50
6.2	Substructure parameters.	51
6.3	Loading parameters	53
6.4	Loading component parameters	53
7.	Appendix 2: The Knowledge Base	53
7.1	Structure Rules	54
7.2	Substructure rules	56
7.3	Loading rules	57
7.4	Loading component rules.	58
	References	60

1 Introduction

In this report we describe an application of artificial intelligence (AI) methods to structural analysis. We describe the development and (partial) implementation of an "automated consultant" to advise non-expert engineers in the use of a general-purpose structural analysis program. The analysis program numerically simulates the behavior of a physical structure subjected to various mechanical loading conditions. The automated consultant, called SACON (Structural Analysis CONSULTant), is based on a version of the MYCIN program [Shortliffe74], originally developed to advise physicians in the diagnosis and treatment of infectious diseases. The domain-specific knowledge in MYCIN is represented as situation-action rules, and is kept independent of the "inference engine" that uses the rules. By substituting structural engineering knowledge for the medical knowledge, the program was converted easily from the domain of infectious diseases to the domain of structural analysis.

1.1 Motivation

The purpose of the consultation is to provide advice to a structural engineer regarding the use of a structural analysis program called MARC [MARC76]. The MARC program uses finite-element analysis techniques to simulate the mechanical behavior of objects. The engineer typically knows *what* s/he wants the MARC program to do, e.g. examine the behavior of a specific structure under expected loading conditions, but does not know *how* the simulation program should be set up to do it. The MARC program offers a large (and, to the novice, bewildering) choice of analysis methods, material properties, and geometries that may be used to model the structure of interest. The user must learn to select from these options an appropriate subset that will simulate the correct physical behavior, preserve the desired accuracy, and minimize the (typically large) computational cost. A year of experience with the program is the typical time required to learn how to use all of MARC's options proficiently. The goal of the automated consultant is to bridge this "What-to-How" gap, by recommending an analysis strategy. This advice can then be used to direct the MARC user in the choice of specific input data, e.g. numerical methods and material properties.

The development of this knowledge-based consultant has been a collaborative enterprise between the Heuristic Programming Project at Stanford University and the MARC Analysis Research Corporation. The primary participants have been Dr. Robert Engelmire, Dr. Lewis Creary and James Bennett of the Heuristic Programming Project, and Dr. Robert Melosh of MARC¹. Dr. Melosh, an expert user of the MARC program, provided the knowledge base that was incorporated in the automated consultant. Bennett, Creary and Engelmire helped elicit the knowledge from Dr. Melosh and implemented and tested the rules in the EMYCIN system (which is essentially the MYCIN program, with the medical knowledge removed).

The collaboration has been mutually beneficial. On the one hand the effort has helped meet a need by the MARC user community for a readily available assistant in

¹ Present address: Dept. of Civil Engineering, Duke University, Durham, N. C. 27705

simulating and analyzing mechanical structures. Moreover, the process of eliciting the knowledge of the domain, in a rule-based form, has sharpened and made more explicit the pertinent information, conceptual elements, framework, and chain of inferences that the human expert actually employs during the structural analysis consulting task. On the other hand, the project has provided an opportunity to apply recent developments in knowledge-based system design to a new field.

1.2 Knowledge-based systems

In recent years there has been a major effort to apply AI techniques in building expert consultation systems. These are programs that contain a large body of specialized knowledge, for the purpose of assisting a user, typically through an interactive exchange. Although these programs may represent their knowledge in many ways -- rules, procedures, semantic nets, lists of facts, etc. -- and apply that knowledge to the specific data in many ways, all these programs achieve high levels of performance by virtue of their extensive knowledge bases. We call such programs knowledge-based systems to distinguish them from programs which attempt to achieve their goals mainly by applying general analytical techniques, without reference to detailed, task-specific knowledge.

1.3 Some examples of knowledge-based systems

In addition to MYCIN, which is discussed in more detail in the next section, a few examples of knowledge-based systems are briefly described below (see also [Waterman78] for an overview as well as an excellent collection of recent research in this area):

- 1) The NUDGE program bears a striking similarity with the consultation program described here, in its relationship with another program as a target of expertise. The NUDGE program accepts informal and possibly incomplete specifications for scheduling a meeting, and transforms them into a formal request to a domain independent scheduling algorithm [Goldstein77].
- 2) The RITA system, a close relative of MYCIN, uses English-like rules for building an "intelligent agent" that assists a terminal user in accomplishing some routine but arcane tasks (e.g., obtaining files over the ARPA network) [Anderson76].
- 3) The PROSPECTOR system is a computer-based consultant for mineral exploration [Duda77]. PROSPECTOR is also closely related to the MYCIN program.
- 4) The CASNET glaucoma consultation program uses a knowledge base organized as a causal association network, to advise clinicians in the diagnosis and treatment of glaucoma [Weiss77].
- 5) The INTERNIST program is a diagnostic consultative program which assists skilled internists in complicated medical problems [Pople77].

- 6) The Heuristic DENDRAL program uses an extensive body of procedural and rule-based knowledge of chemistry and mass spectrometry to infer chemical structures from mass spectrometry data [Buchanan71].
- 7) The Meta-DENDRAL program examines examples of known chemical structures and their associated mass spectra, and formulates the rules of mass spectrometry that the Heuristic DENDRAL program can use [Buchanan76].
- 8) The Exemplary Programming (EP) system "looks over the shoulder" of the user and transforms the sample interaction between the user and the computer into a general procedure capable of performing that class of tasks in the future [Waterman78a].

1.4 Scope of this report

The SACON program, as mentioned above, is an application of AI techniques that were originally implemented in the MYCIN system. MYCIN's approach to the organization of the consultation task is discussed in Section 2. The scope of the structural mechanics consultation, the types of rules which capture the domain knowledge, the context tree, and other features of the system as it is applied to our specific task are described in Section 3. Two applications of the consultation program, one an analysis of a 747 wing, the other an analysis of a building, are presented in Section 4, with actual terminal output from the program (annotated for additional clarity). Finally, in Section 5, we draw some conclusions about the use of automatic consultation in the structural design process and a discussion of possible extensions to this work. Appendix 1 contains the parameters definitions used by the model discussed in Section 3, and Appendix 2 contains a representative subset of the rules used in this prototype version of SACON.

2 Computer consultants and the EMYCIN system

The recent growth of interest in the class of programs known as computer consultants can be seen as a logical consequence of two trends: an emphasis on large stores of domain-specific knowledge and the concentration on problems taken from real world settings. These programs are intended to provide expert-level advice on difficult cognitive problems, particularly ones for which human expertise is in short supply.

One such system, MYCIN [Shortliffe74], was originally designed to provide consultative advice on diagnosis and therapy for infectious diseases. Such advice is often required in the hospital because the attending physician is not an expert on infectious disease--as, for example, when a cardiology patient develops an infection after heart surgery. Time considerations compound the problem. A specimen (blood, urine, etc.) from a patient can show some early evidence of bacterial growth within 12 hours, but 24 to 48 hours (or more) are usually required for positive identification. The physician must therefore often decide in the absence of complete information whether or not to start treatment and what drugs to use if treatment is required. Both of these may be difficult questions.

In accordance with one of its primary design criteria, MYCIN was written in such a way as to maintain a clear distinction between the knowledge base and the inference engine. This makes it possible to remove the medical knowledge base, leaving only the general facilities for interviewing, inference, explanation, etc. This "empty" version of the consultation program, called EMYCIN, has been used not only for this project but other domains as well, including the repair of car horns [vanMelle74], recommendations for pulmonary function therapy [Feigenbaum77], and psychiatric diagnosis and chemotherapy [Heiser78]. In each of these systems the general consultation facilities worked without modification.

The following typescript shows the initial and final parts of a sample interaction between a user and the SACON program as adapted for the structural analysis domain. SACON in effect "interviews" the user about his structure, collecting information that will allow it to infer the an appropriate analysis strategy for the numerical simulation. More detailed examples are given in Section 4.

2.1 A short example

July 26, 1978 10:54AM in <SACON>MARC.SAV;80709 by SACON

Hello Dr. Melosh,

THIS CONSULTATION CONCERNS THE 747 WING. THE PURPOSE OF THE CONSULTATION IS TO DEMONSTRATE THE GENERAL FEATURES OF A STRUCTURAL ANALYSIS CONSULTATION ON A SIMPLE PROBLEM. THUS THE CONSULTATION INVOLVES ONLY ONE SUBSTRUCTURE: THE TOTAL WING.

26-Jul-78 10:54:44
[consultation of 13-Jul-78 1:55PM]

-----STRUCTURE-28-----

- 1) What is the name of STRUCTURE-28?
** BOEING 747 WING
- 2) Assuming that your characterization of the boeing 747 wing in terms of its geometry, material characteristics, and boundary conditions are accurate, how much error (in percent) is tolerable for the analysis?
** 10
- 3) Do you want to examine the responses of the boeing 747 wing , to evaluate its instability, or both?
** EXAMINE-RESPONSES
- 4) Does the boeing 747 wing have any time dependent terms in its equations of equilibrium?
** NO
- 5) Is heating or cooling of interest in determining structure responses?
** NO
- 6) Have you decomposed the boeing 747 wing into a number of potential sub-structures which are relevant to this analysis?
** YES

-----SUB-STRUCTURE-1-----

- 7) What is the name of SUB-STRUCTURE-1?
** TOTAL WING
- 8) What is the material composing most of the total wing (SUB-STRUCTURE-1)?
** HIGH-STRENGTH-ALUMINIUM
- 9) Enter the average longest dimension of the total wing (SUB-STRUCTURE-1) in inches (or <number> CMS):
** 1420
- 10) Enter the weight of the total wing (SUB-STRUCTURE-1) in pounds (or <number> KGS):
** 46000
- 11) Is the total wing (SUB-STRUCTURE-1) thin-walled or solid?
** THIN-WALLED
- 12) What is the configuration of support for the total wing (SUB-STRUCTURE-1)?
** ONE-SIDE
- 13) Is the total wing (SUB-STRUCTURE-1) to be modelled as a 1, 2, or 3 dimensional system?
** 2
- 14) Would you describe the construction of the total wing (SUB-STRUCTURE-1) to be truss and/or frame elements (NETWORK), sheets

and/or blocks of material (CONTINUUM), or a combination of both?

** CONTINUUM

15) Is the overall geometry of the total wing (SUB-STRUCTURE-1) curved or planar?

** PLANAR

The first loading applied to the total wing (SUB-STRUCTURE-1) will be called:

-----LOADING-1-----

16) What is the name of LOADING-1?

** FLIGHT

17) Enter the number of loading cycles to be applied:

** 20000

The first load component associated with LOADING-1 will be called:

-----LOAD-COMPONENT-1-----

18) Would you describe LOAD-COMPONENT-1 as being DISTRIBUTED over most of the sub-structure or as acting at a POINT of the sub-structure?

** DISTRIBUTED

19) Which surface of the sub-structure does LOAD-COMPONENT-1 act NORMAL to? (If more than one surface, you should consider the loading as two or more component loadings)

** WIDTH-LENGTH

20) Enter the average wall thickness of the total wing (SUB-STRUCTURE-1) in inches (or <number> CMS):

** .31

21) Enter the average depth of the total wing (SUB-STRUCTURE-1) in inches (or <number> CMS):

** 41

22) Enter the magnitude of the distributed load (in psi):

** 1

23) Are there any other load components associated with LOADING-1?

** NO

24) Are there any other loading conditions associated with the total wing (SUB-STRUCTURE-1)?

** NO

25) Are there any other sub-structures of the boeing 747 wing relevant to this analysis?

** NO

26) Do the supports of the boeing 747 wing involve Coulomb friction, nonlinear springs, and/or gapping?

** NO

The following analysis classes are relevant to the analysis of your structure:

1) general-inelastic

(The following recommendations apply to this case:)

Activate incremental stress - incremental strain analysis.

Model nonlinear stress-strain relation of the material.

Solution will be based on a mix of gradient and Newton methods.

Logic to scan peak stress at each step and evaluate fatigue integrity should be used.

Logic to scan stresses, smooth, and compare with allowable stresses (with appropriate safety factors) should be used.

Logic to scan deflections, calculate relative values, and compare with code limits, should be called upon.

Cumulative strain damage should be calculated.

Analysis should include two or more load cycles (if cyclic) with extrapolation for strain accumulation.

Shakedown extrapolation logic should be used.

A single cycle of loading is sufficient for the analysis.

Do you wish advice on another structure?

** NO

2.2 Knowledge base organization

2.2.1 Production rules

The performance program operates with knowledge which is encoded as inference rules in the form shown by the following example:

RULE050

```

-----
If:  1) The material composing the sub-structure is
      one of: the metals, and
      2) The analysis error (in percent) that is tolerable is
         between 5 and 30, and
      3) The non-dimensional stress of the sub-structure is
         greater than .9, and
      4) The number of cycles the loading is to be applied is
         between 1000 and 10000
Then: It is definite (1.0) that fatigue is one of the
      stress behavior phenomena in the sub-structure

PREMISE:  ($AND (SAME CNTXT MATERIAL (LISTOF METALS))
              (BETWEEN* CNTXT ERROR 5 30)
              (GREATERP* CNTXT ND-STRESS .9)
              (BETWEEN* CNTXT CYCLES 1000 10000))
ACTION:   (CONCLUDE CNTXT SS-STRESS FATIGUE TALLY 1.0)
  
```

The rules are stored internally in the INTERLISP [Teitelman75] form shown, from which the English version is generated. Each rule is a single "chunk" of domain-specific knowledge indicating an ACTION (in this case a conclusion) to be performed if the conditions specified by the PREMISE are fulfilled. Note that the rules are judgmental, that is, they may make inexact inferences. In the case of the example rule the evidence cited in the premise is strong enough to assert the conclusion shown with a high degree of confidence: 1.0 out of 1.0. This number is called a "certainty factor," or CF, and embodies a model of confirmation described in [Shortliffe75]. The details of this model need not concern us here; we need only note that rules in this case are typically inexact inferences. (In our prototype system, however, all rules have a certainty factor of 1.)

The premise of each rule is a Boolean combination of one or more clauses, each of which is constructed from a predicate function with an associative triple (attribute, object, value) as its argument. Thus each clause of a typical premise has the following four components:

<predicate function> <object> <attribute> <value>

For the first clause in the premise of the example rule, the predicate function is SAME, and the triple is "material of sub-structure is one of: the metals." CNTXT is a free variable which is bound to the specific object [also called a "context"] for which the rule is invoked. There is a standardized set of some 24 domain-independent predicate functions (e.g., SAME, KNOWN, DEFINITE) and a range of domain-specific attributes (e.g., MATERIAL,

GEOMETRY), objects (e.g., STRUCTURE, LOADING), and associated values (e.g., ALUMINUM, CURVED). These form a "vocabulary" of conceptual primitives available for use in constructing rules.

A rule premise is always a conjunction of clauses, but may contain arbitrarily complex conjunctions or disjunctions nested within each clause. (Instead of writing rules whose premise would be a disjunction of clauses, a separate rule is written for each clause.) The action part indicates one or more conclusions that can be drawn if the premises are satisfied, making the rules purely inferential.

Each rule is intended to embody a single, independent chunk of knowledge and states all necessary information explicitly in the premise. Since the rule uses a vocabulary of concepts common to the domain, it forms, by itself, a comprehensible statement of some piece of domain knowledge. This characteristic facilitates rapid modification of the knowledge base, and allows explanations of the program's line of reasoning [Scott77]. Moreover, since each rule has a highly stylized, if/then format, and uses a specified set of available primitives, the rule itself (in its LISP form) is a piece of executable code.

2.2.2 Associative triples and confidence factors

Facts about the world are represented as 4-tuples made up of an associative triple and its current certainty factor. Positive CFs indicate a predominance of evidence confirming a hypothesis; negative CFs indicate predominance of disconfirming evidence.

```
(SS-STRESS SUB-STRUCTURE-1 FATIGUE 1.0)
(SS-STRESS SUB-STRUCTURE-1 YIELDING-COLLAPSE 1.0)
(ANALYSIS-CLASS STRUCTURE-1 GENERAL-INELASTIC 1.0)
```

Note that it is possible for some attributes to be multi-valued. For example, after attempting to deduce the stress behavior (SS-STRESS) of a sub-structure, SACON may conclude (correctly) that there is evidence both for fatigue and for yielding-collapse.

2.2.3 Context tree

The final aspect of the knowledge structure is the tree of objects (or contexts) that is constructed dynamically from a fixed hierarchy as the consultation proceeds. This tree serves several purposes. First, bindings of free variables in a rule are established by the context in which the rule is invoked, with the standard access to contexts that are its ancestors. Second, since this tree is used to represent the relationships of objects in the domain, it helps structure the consultation in ways already familiar to the user.

For example, in the structural analysis domain, a structure has one or more sub-structures, each of which may have one or more associated loadings, each of which in turn may have one or more load-components composing it, as shown in Figure 2.1.

There are thus three major forms of knowledge representation used in the performance program:

- 1) rules of inference are represented as production rules;
- 2) facts are represented as associated triples (attribute, object, value);
- 3) the hierarchy of objects is represented as a context tree.

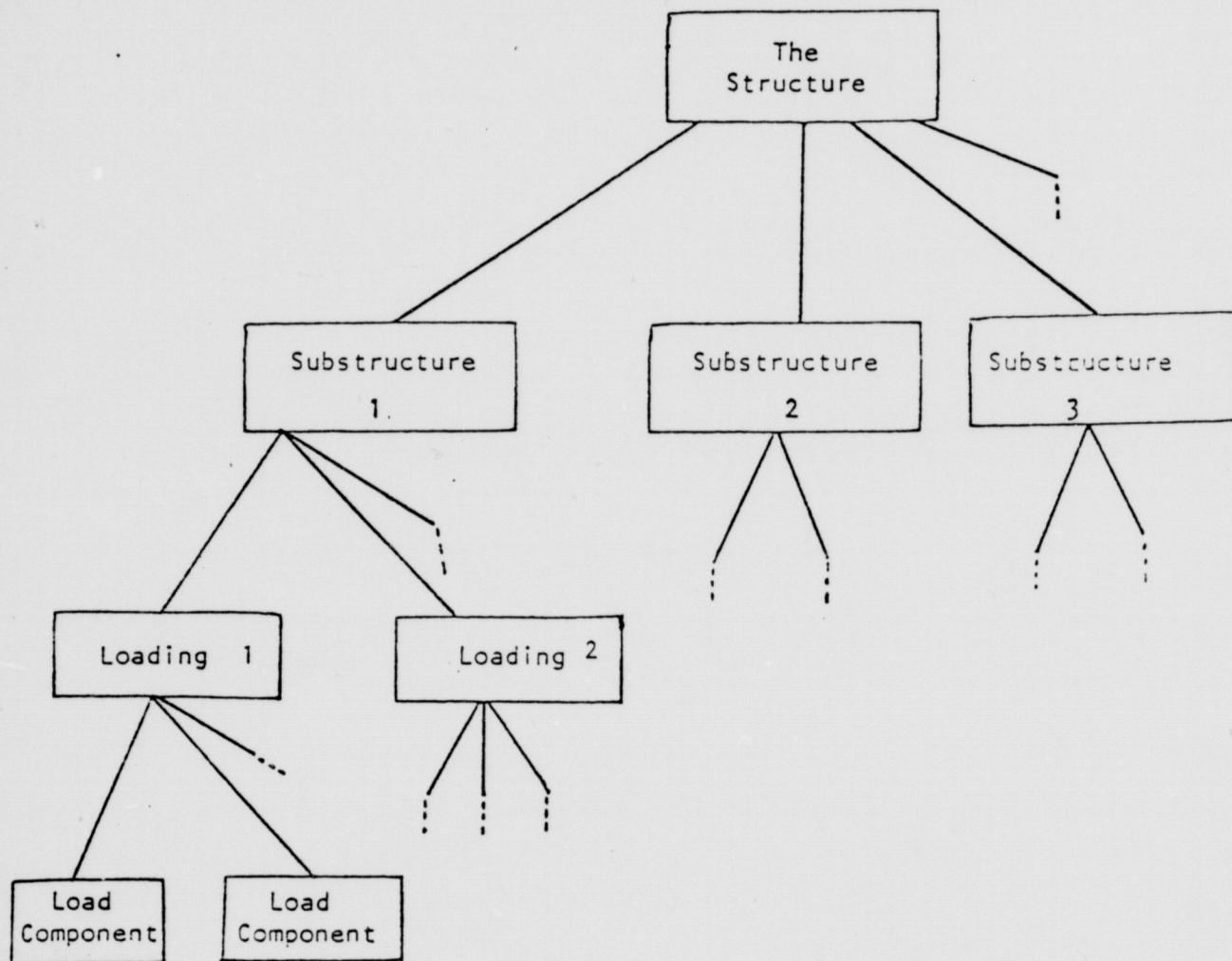

Figure 2.1 - Context Tree

2.3 The inference engine

The rules are invoked in a simple backward-chaining fashion that produces a depth-first search of a goal tree. To illustrate, assume that the program is attempting to determine the stress behavior of a substructure. It retrieves all the rules that make a conclusion about that topic (i.e., they mention SS-STRESS in their action), and invokes each one in turn, evaluating each premise to see if the conditions specified have been met. For the example rule, this process would begin with determining the type of material composing the substructure. This, in turn, is set up as a subgoal and the process recurs.

The search is thus depth-first (because each premise condition is thoroughly explored in turn), and the search is exhaustive (because the rules may be inexact, so that even if one succeeds, the conservative strategy is to continue to collect all evidence about the subgoal.)

Note that the subgoal that is set up is a generalized form of the original goal. Thus, for the first clause in the example ("the material composing the sub-structure is one of the metals"), the subgoal set up is "determine the material." The subgoal is therefore always of the form "determine the value of <attribute>" rather than "determine whether the <attribute> is equal to <value>." By setting up the generalized goal of collecting all evidence about an attribute, the performance program treats each subject as it is encountered, and thus tends to group together all questions about a given topic. This results in a system that displays a much more focused, methodical approach to the task, which is a distinct advantage where human engineering considerations are important.

If, after trying all relevant rules (referred to as "tracing" the subgoal), the system is unable to deduce the value of an attribute, the answer is regarded as still unknown. This may happen if no rules are applicable, if the applicable rules are too weak, if the effects of several rules offset each other, or if there are no rules for this subgoal at all. In any of these cases, when the system is unable to deduce the answer, it asks the user for the value of the subgoal (using a phrase that is stored along with the attribute itself).

The strategy of always attempting to deduce the value of a subgoal, asking the user only when deduction fails, insures a minimum number of questions. However, that strategy might also lead to unnecessary work searching for a subgoal, arriving perhaps at a less than definite answer, when the user already knows the answer with certainty. To prevent this inefficiency, some of the attributes have been labeled "laboratory data," to indicate that they represent information available to the engineer at the start of the consultation. In these cases the deduce-then-ask procedure is reversed and the system will attempt to deduce the answer only if the user cannot supply it. Given the desire to minimize both tree search and the number of questions asked, there is no guaranteed optimal solution to the problem of deciding when to ask for information and when to try to deduce it. Allowing both types of strategies has been found to be a practical and effective solution.

Two other additions to straightforward tree search increase the inference engine's efficiency. First, before the entire list of rules for a subgoal is retrieved, the program attempts to find a sequence of rules that would establish the goal with certainty, based only on what is currently known. Since this is a search for a sequence of rules with $CF=1$, the

result is termed a "unity path". Besides efficiency considerations, this process offers the advantage of allowing the program to make "common sense" deductions with a minimum of effort.

Second, the inference engine performs a partial evaluation of rule premises. Since many attributes are found in several rules, the value of one clause (perhaps the last) in a premise may already have been established while the rest are still unknown. If this clause alone would make the premise false, there is clearly no reason to do all the search necessary to establish the others. Each premise is thus "previewed" by evaluating it on the basis of currently available information. This produces a Boolean combination of TRUES, FALSEs, and UNKNOWNS; straightforward simplification (e.g., $F \& U = F$) indicates whether the rule is guaranteed to fail.

To summarize, the rule-based formalism adopted here for representing the consultant's knowledge has several advantages over more traditional techniques, e.g., decision trees. These advantages derive mainly from the inherent modularity of the rules. Each rule is a relatively independent module or "chunk" of knowledge. The knowledge base is thus easy to understand and modify.

Usually, one can make a desired change in the decision logic by adding, changing, and/or deleting just a few rules. In contrast, a relatively small change in the decision-tree formalism can require the rewriting of an entire decision tree, since the features changed may be embedded deeply in the structure of a particular tree. Furthermore, provided that the size of the "knowledge chunks" is properly chosen, the production rule representation permits intelligible explanations of particular conclusions. Lines of reasoning can be displayed on demand, using traces of the rule interpretation process (an example of the explanation facility is given in Section 4).

Other schemes for implementing an automated consultant are, of course, possible. A decision tree, for example, could be constructed that is equivalent to any particular set of production rules (i.e. the same questions would be asked and the same conclusions would be reached), and the object program would run more efficiently. The decision to use a rule-based representation as described above is analogous to the decision to write a program in a high-level language like FORTRAN rather than in machine language; the advantages (ease of modification, intelligibility, etc.) and disadvantages (slower to execute, uses more space, etc.) are much the same. A method for compiling a rule base into an equivalent decision tree is currently under development, thereby combining the best features of both techniques.

In the following two sections of this report we present the details of the structural analysis knowledge base and discuss two cases that were treated by the consultant.

3 The Structural Mechanics Knowledge Base

This section presents the details of the knowledge base used in SACON. The objective of a consultation is to identify an analysis strategy for a particular structural analysis problem. The engineer can then implement this strategy, using the MARC program, to evaluate the material behaviors of his structure. This section defines the mathematical and physical models used for characterizing the structure and recommending an analysis strategy.

3.1 Analysis Strategies

An analysis strategy consists of an *analysis class* and a number of associated *analysis recommendations*. An analysis class is an indication of the complexity of modelling and the ability to analyze the material behaviors of the structure. Table 3.1 lists the 38 analysis classes currently considered. The analysis recommendations advise the engineer on specific features of the MARC program that should be activated when performing the actual structural analysis. The example consultation of the previous section concludes with ten such recommendations.

Table 3.1 Analysis Classes

- Nonlinear-geometry-crack-growth
- Nonlinear-geometry-stress-margin
- Nonlinear-geometry-fatigue
- Buckling
- Bifurcation
- Nonlinear-geometry-excessive-deflection
- Stiffness-degradation
- Nonlinear-geometry-strength
- Nonlinear-geometry-deflection
- Inelastic-crack-growth
- Inelastic-stress-failure
- Material-instability
- Inelastic-collapse
- Inelastic-fatigue
- Inelastic-strain-accumulation-failure
- Elastic-plastic-collapse
- Inelastic-excessive-deflection
- Inelastic-stiffness-degradation
- Inelastic-strength
- Inelastic-deflection
- Nonlinear-crack-growth
- Nonlinear-stress-margin
- Nonlinear-material-instability
- Nonlinear-yielding-collapse

Table 3.1(continued)

Nonlinear-fatigue
 Nonlinear-strain-accumulation
 Nonlinear-buckling
 Nonlinear-bifurcation
 Nonlinear-excessive-deflection
 Nonlinear-stiffness-degradation
 Nonlinear-strength
 Nonlinear-deflection
 Nonlinear-boundary-condition
 General-large-displacement
 General-inelastic
 General-nonlinear
 Linear-analysis
 No-analysis

3.2 Material Behaviors

To determine the appropriate analysis strategy, SACON estimates the critical material behaviors, i.e. stresses and deflections, of a structure under a number of loading conditions. The material behaviors currently known to SACON are listed in Table 3.2. Typical structures that can be analyzed by both SACON and MARC include aircraft wings, reactor pressure vessels, rocket motor casings, bridges, buildings, etc.

Table 3.2 Types of stress and deflection behaviors

Stress Behaviors	Deflection Behaviors
Stress-compared-with-allowables	Excessive-deflection
Yielding-collapse	Flexibility-changes
Cracking-potential	Incremental-strain-failure
Fatigue	Buckling
Material-instabilities	Load-path-bifurcation
Stress-exceedence	Kinematic-collapse-load

3.3 Substructures

Using SACON, the engineer decomposes the structure into one or more *substructures* to determine the most aggravated stress and displacement conditions. He provides the system data describing the materials, general geometries, and boundary conditions for each of these substructures. A substructure is a geometrically contiguous region of the structure, composed of a single material such as high-strength aluminum or structural steel, and having a specified set of kinematic boundary conditions. A structure may be subdivided in a number of different ways. Figure 3.1 illustrates some of these possibilities. A particular choice of decomposition is made which best reveals the worst case behaviors of the structure.

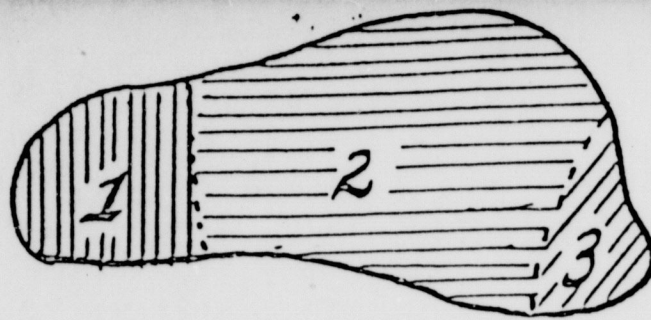

(a)

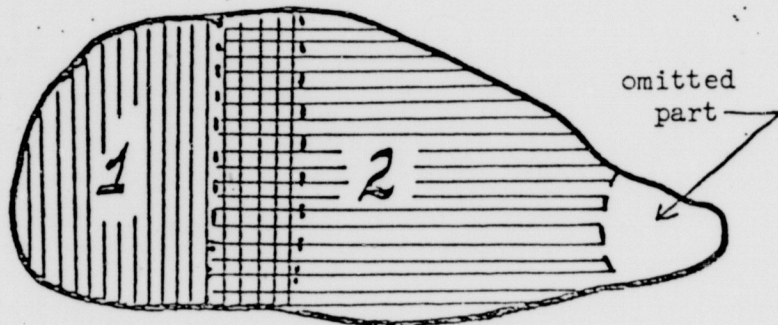

(b)

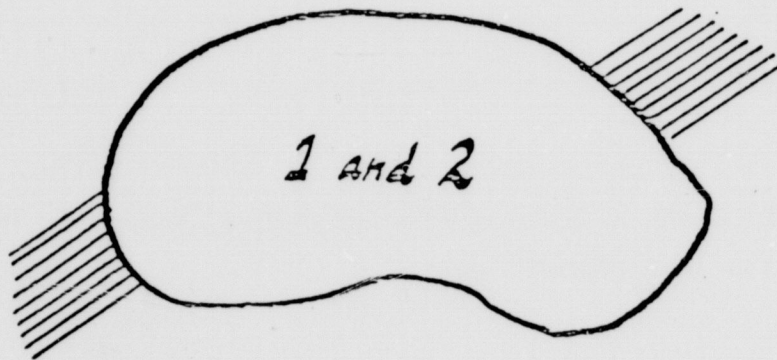

boundary
condition
for
substructure 2

boundary
condition
for
substructure 1

(c)

Fig. 3.1 Methods of Substructuring. (a) depicts the conventional substructure concept of finite element analysis. The structure is divided into non-overlapping regions, where every distinct part of the structure falls into a substructure or onto a boundary shared by substructures. (b) shows substructuring using overlapping substructures and the exclusion of a part. (c) illustrates decomposition into two substructures to permit a selection of peak responses from two different models of the substructure's kinematic boundary conditions.

3.4 Loadings

For each substructure SACON estimates a *total loading* from one or more *loadings*. Each loading applied to a substructure represents one of the typical mechanical forces on the substructure during its working life. ¹ These might include loadings experienced during various maneuvers such as braking, banking, etc. or caused by natural phenomena such as earthquakes or wind-storms. Each loading is in turn composed of a number of point or distributed *load components*.

3.5 Major Reasoning Steps

Given the descriptions of the component substructures and descriptions of the loadings applied to each substructure, the consultant estimates stresses and deflections for each substructure using a number of simple mathematical models. The behaviors of the complete structure are found by determining the sum of the peak relative stress and deflection behaviors of all the substructures. Based on these peak responses (essentially the worst-case behaviors exhibited by the structure), knowledge of available analysis types, and the tolerable analysis error, SACON recommends an analysis strategy. Figure 3.2 illustrates the information flow during a consultation.

¹ The prototype SACON program contains no rules for time-dependent or thermal loading conditions. The currently implemented strategies apply only to structures whose equilibrium equations are time independent and assume that the structure is fabricated and loaded at room temperature (21 deg. C).

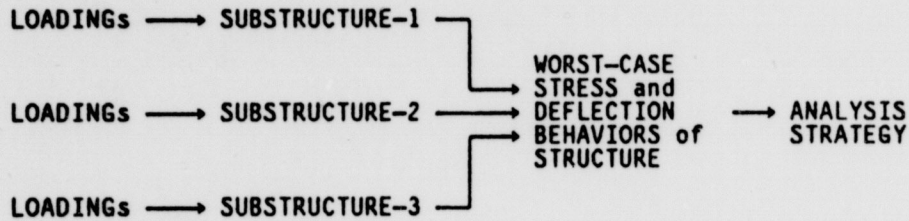

Fig. 3.2 Information flow during the consultation. The user specifies loading and substructure descriptions that SACON uses to infer material behaviors and, finally, an analysis strategy.

3.6 The Mathematical Model

The loading data and knowledge about the overall geometry of each of the substructures enable the consultant to model each substructure as either a network of trusses and beams or as a continuum of material. Network models imply beam-like behavior; continuum models imply plate-like behavior. The cross-section of a substructure may be treated as solid or thin-walled. In a solid section, all the material in the section resists loading. In a thin-walled section, that part of the material resisting loading is centered near the section boundaries. A solid bar or a hollow tube illustrate a solid or thin-walled section, respectively.

Example rules using formulas for the plate and beam models are given in Appendix 2. These formulas estimate peak stresses and relative deflection given the number of edges supported, the geometry of the panel, the material stiffness, the form of the cross section, and the location and magnitude of loadings.

The stresses and deflections due to each loading component are summed to determine stress and deflection bounds for a particular loading. The root-mean-square of these loading bounds is computed to arrive at non-dimensional limiting-response estimates for each substructure. These estimates are used to determine what stress, deflection, and nonlinear behaviors will be displayed by each substructure. Finally, an appropriate analysis strategy is determined by considering the most severe stress state and the greatest deflection change for any of the substructures of the structure.

3.7 Summary

Thus there are three major types of knowledge implemented and used by the system:

- 1) The mathematical models that estimate non-dimensional stress and deflection bounds for each substructure, given its boundary conditions and its loadings.
- 2) Methods for inferring stress, deflection, and nonlinear behaviors of substructures, given the non-dimensional response bounds, the number of loading cycles are to be applied, the material composition of the substructure, and the tolerable analysis error.
- 3) Rules for inferring analysis strategies (both analysis class and recommendations) depending on the worst-case stress, deflection, and nonlinear behaviors of the structure.

The existing knowledge base is able to select from among 36 nonlinear analysis strategies. If nonlinear analysis is not indicated by the response estimates, the consultation recommends linear analysis. In addition, if relative stress and displacement estimates are low (less than five percent of critical values), the consultation indicates no analysis is required. The knowledge base consists of 170 rules and about 140 consultation parameters. A typical consultation (2 substructures, 3 loadings, 3 load components) requires about 25 minutes at an interactive terminal.

To reiterate a point made in Section 2, all of SACON's knowledge is represented as a set of production rules. This representation permits the knowledge to be separated from the "inference engine" which uses it. The knowledge base is thus a data structure, as distinct from the program as the input data. Consequently the domain of expertise of the consultation system may be expanded by adding new rules, without changing the program.



4 Example Consultations

This section illustrates the features of the structural analysis consultation in more detail. It exhibits consultations for an airplane wing and a reinforced concrete building, thereby showing the scope of the knowledge base and MYCIN code features in structural analysis consultations.

4.1 Analysis of an Airplane Wing

Figure 4.1 provides a schematic of the wing of a Boeing 747 and a tabulation of some wing loadings. The problem is to determine what analysis strategy to use to evaluate the structural integrity of the wing for the loadings given.

The swept wing is tapered in planform and in depth. Skin gauges vary from .500 inches at the 770-inch root chord to .120 inches at the 220-inch tip chord. The wing is fabricated of high-strength aluminum. Wing loadings of interest include normal flight and landing in a fully fueled configuration.

Figure 4.2 summarizes the engineer's decomposition of the structure. The wing is partitioned into three substructures--the outer wing, the inner wing, and the total wing. Three substructures are used to deal more accurately with the wing geometry. All three are assumed to be supported at their inboard edge and subjected to the two independent loadings.

The dialogue of the consultation is reproduced below. The user's responses to SACON's questions, or his requests for information, are preceded by a double asterisk. Annotations which are not part of the actual dialogue are in *italics* and prefaced by *NOTE*.

AIRPLANE WING ANALYSIS (747)

Analysis Model

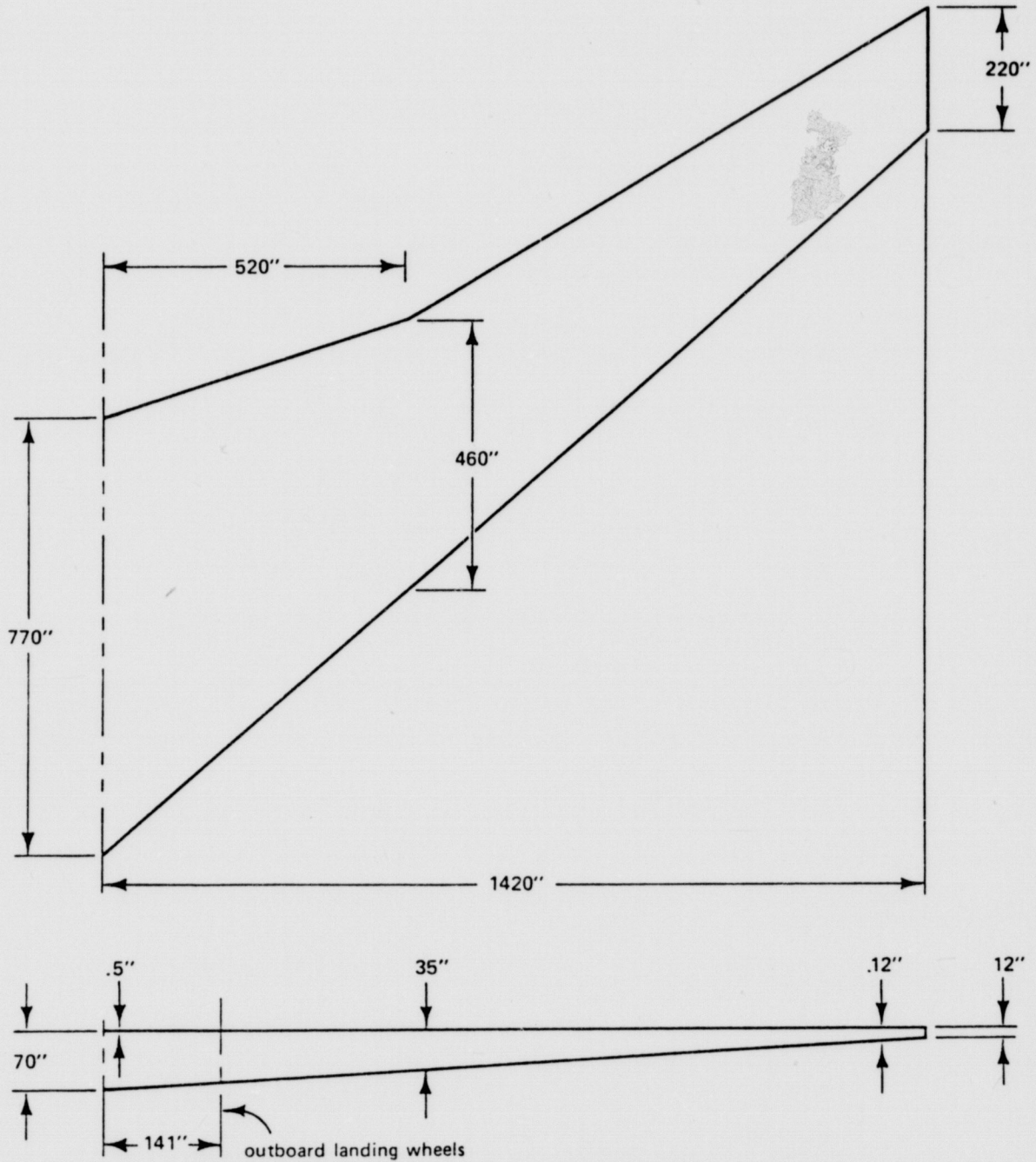

<u>CONFIGURATION</u>	<u>WING WT.</u>	<u>LIFTING LOAD</u>	<u>CYCLES</u>
Fully-fueled flight	6.4 psi	7.4 psi	20000
Fully-fueled, landing	3.0 psi	17,600# out. wheels 55,900 at body	20000

Fig. 4.1

C. Substructure 3-Total Wing

Weight = 46000

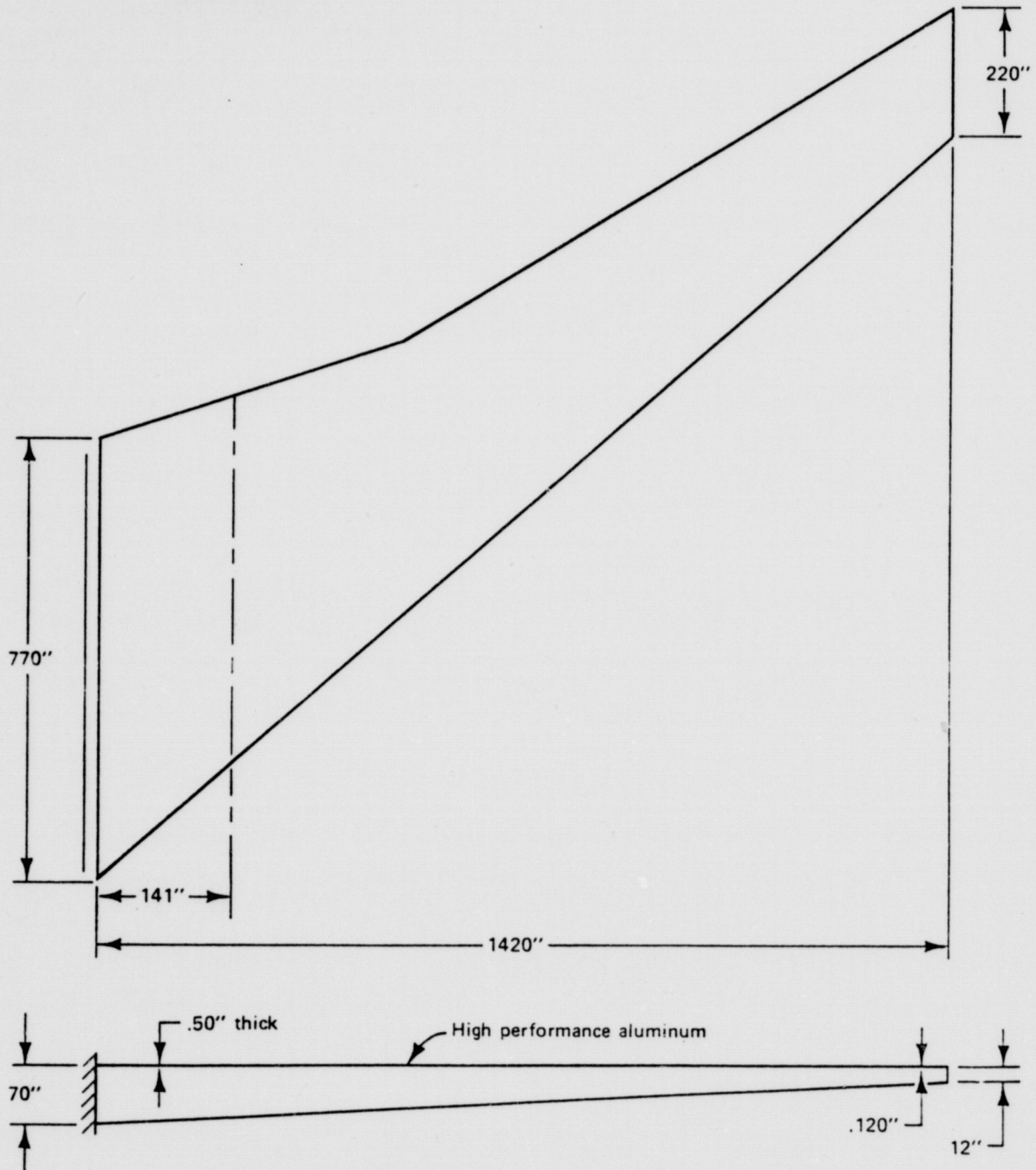

<u>LOADING</u>	<u>WING DEAD WT.</u>	<u>WING LIFT</u>	<u>CYCLES</u>
Flight	6.4 psi	-7.4 psi	20000
Landing	3.0 psi	-17,600 # at 141"	20000

Fig. 4.2 (cont.)

CONSULTATION MODEL (747 Wing)

A. Substructure 1—Outer Wing

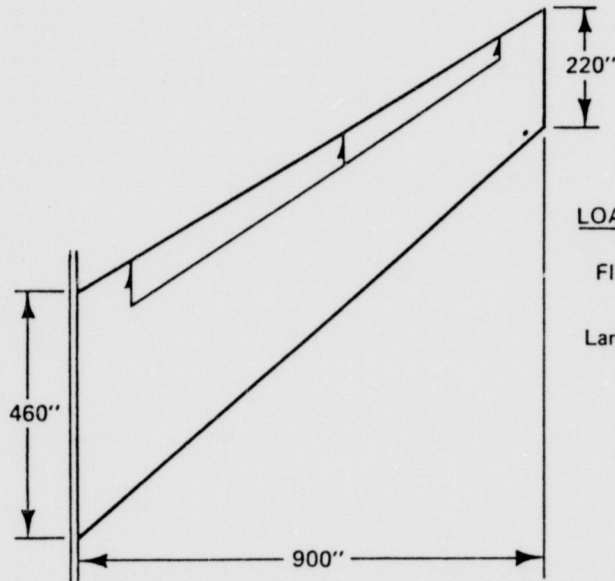

LOADING	WING DEAD LOAD	WING PRESSURE	CYCLES
Flight	6.4 psi	-7.4 psi	20000
Landing	3.0 psi	-----	20000

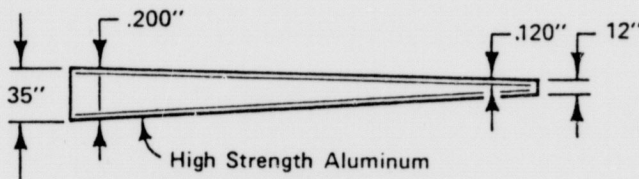

B. Substructure 2— Inner Wing

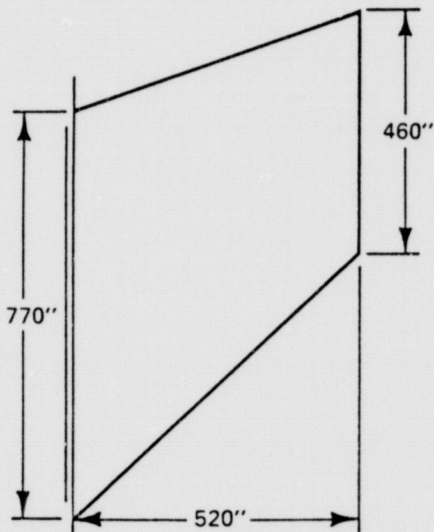

LOADING	WING DEAD LOAD	WING LIFT	CYCLES
Flight	6.4 psi	-7.4 psi	20000
Landing	3.0 psi, 918,000 # from outer wing substructure	17,600 # at outboard wheels	20000

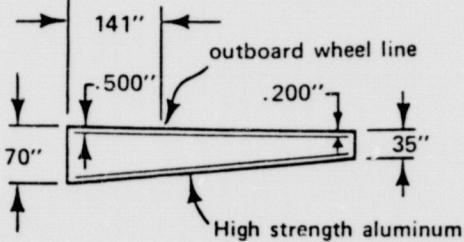

Fig. 4.2

September 9, 1978 10:10AM in <SACON>SACON.SAV;80908 by SACON

Loading <SACON>STRUCTURE.1;1...

THIS IS THE CONSULTATION FOR THE 747 WING. THE PURPOSE OF THIS EXAMPLE IS TO ILLUSTRATE A TYPICAL CONSULTATION. THUS, IT DEALS WITH MULTIPLE SUBSTRUCTURES (3), LOADINGS (5), AND LOADING COMPONENTS. IT ASSUMES THAT THE ANALYSIS OBJECTIVE IS TO EVALUATE RESPONSE INTEGRITY UNDER LOADINGS CAUSED BY FLIGHT AND LANDING CONDITIONS.

-----STRUCTURE-1-----

1) What is the name of STRUCTURE-1?

** 747 WING

2) Assuming that your characterization of the 747 wing in terms of its geometry, material characteristics, and boundary conditions are accurate, how much error (in percent) is tolerable for the analysis?

** 5

3) Do you want to examine the responses of the 747 wing, to evaluate its instability, or both?

** EXAMINE-RESPONSES

4) Does the 747 wing have any time dependent terms in its equations of equilibrium?

** NO

5) Is heating or cooling of interest in determining structure responses?

** NO

6) Have you decomposed the 747 wing into a number of potential sub-structures which are relevant to this analysis?

** YES

-----SUB-STRUCTURE-1-----

7) What is the name of SUB-STRUCTURE-1?

** OUTER WING

8) What is the material composing most of the outer wing (SUB-STRUCTURE-1)?

** HIGH-STRENGTH-ALUMINIUM

9) Enter the average longest dimension of the outer wing (SUB-STRUCTURE-1) in inches (or <number> CMS):

** 900

10) Enter the weight of the outer wing (SUB-STRUCTURE-1) in pounds (or <number> KGS):

** 14000

11) Is the outer wing (SUB-STRUCTURE-1) thin-walled or solid?

** THIN-WALLED

12) What is the configuration of support for the outer wing (SUB-STRUCTURE-1)?

** ONE-SIDE

13) Is the outer wing (SUB-STRUCTURE-1) to be modelled as a 1, 2, or 3 dimensional system?

** 2

14) Would you describe the construction of the outer wing (SUB-STRUCTURE-1) to be truss and/or frame elements (NETWORK), sheets and/or blocks of material (CONTINUUM), or a combination of both?

** CONTINUUM

15) Is the overall geometry of the outer wing (SUB-STRUCTURE-1) curved

or planar?
 ** WHY

(NOTE: The user may respond to any question with "WHY". The consultant then attempts to explain its current line of reasoning by describing the sub-goal that it is trying to establish.)

[i.e. WHY is it important to determine the geometry of SUB-STRUCTURE-1?]
 [1.0] This will aid in determining the shape of SUB-STRUCTURE-1.

It has already been established that
 [1.1] the modelling dimensionality of the outer wing is 2
 Therefore, if
 [1.2] it is known uniquely that continuum is one of the constructions
 of the outer wing, and
 [1.3] the geometry of the outer wing is planar
 then
 it is definite (1.0) that the shape of the outer wing is plate

[back to question 15 ...]

** CURVED

The first loading applied to the outer wing (SUB-STRUCTURE-1) will be called:

-----LOADING-1-----

16) What is the name of LOADING-1?

** FLIGHT

17) Enter the number of loading cycles to be applied:

** 20000

The first load component associated with LOADING-1 will be called:

-----LOAD-COMPONENT-1-----

18) Would you describe LOAD-COMPONENT-1 as being DISTRIBUTED over most of the sub-structure or as acting at a POINT of the sub-structure?

** WHY

(NOTE: Another user request for an explanation of what the consultant is trying to accomplish by asking the question.)

[i.e. WHY is it important to determine the distribution of LOAD-COMPONENT-1?]

[2.0] The distribution of a load component is one of the 4 standard parameters that identify a load component.

This may be useful later in the consultation. For example, it is very important in determining the stress magnitude of LOAD-COMPONENT-1 and is very important in determining the deflection magnitude of LOAD-COMPONENT-1.

[back to question 18...]

** DISTRIBUTED

19) Which surface of the sub-structure does LOAD-COMPONENT-1 act NORMAL to? (If more than one surface, you should consider the loading as two or more component loadings)

** WIDTH-LENGTH

20) Enter the average wall thickness of the outer wing (SUB-STRUCTURE-1) in inches (or <number> CMS):

** .16

21) Enter the average depth of the outer wing (SUB-STRUCTURE-1) in inches (or <number> CMS):

** 23.5

22) Enter the magnitude of the distributed load (in psi):

** WHY

(NOTE: Another example of the explanation facility.)

[i.e. WHY is it important to determine the magnitude of LOAD-COMPONENT-1 (in psi)?]

[3.0] This will aid in determining the stress magnitude of LOAD-COMPONENT-1 (in psi).

It has already been established that

[3.1] the surface to which LOAD-COMPONENT-1 acts normal is width-length, and

[3.2] the distribution of LOAD-COMPONENT-1 is distributed, and

[3.3] the configuration of support for the outer wing is one-side, and

[3.4] the shape of the outer wing is one of: the surface shapes, and

[3.5] the moment of inertia of the outer wing is known, and

[3.6] the length of the outer wing is known, and

[3.7] the depth of the outer wing is known, and

[3.8] Young's modulus of the material is known

Therefore, if

[3.9] the magnitude of LOAD-COMPONENT-1 (in psi) is known

then

it is definite (1.0) that the stress magnitude of LOAD-COMPONENT-1 (in psi) is $\text{depth} * \text{dist-mag} * \text{length} \uparrow 2 / 4 * \text{einertia}$

[ALSO:

it is definite (1.0) that the deflection magnitude of LOAD-COMPONENT-1

in inches is $\text{dist-mag} * \text{length} \uparrow 3 / 24 * \text{youngs-modulus} * \text{einertia}$]

[back to question 22...]

** 1

23) Are there any other load components associated with LOADING-1?

** NO

24) Are there any other loading conditions associated with the outer wing (SUB-STRUCTURE-1)?

** YES

-----LOADING-2-----

25) What is the name of LOADING-2?

** LANDING

26) Enter the number of loading cycles to be applied:

** 20000

The first load component associated with LOADING-2 will be called:

-----LOAD-COMPONENT-2-----

27) Would you describe LOAD-COMPONENT-2 as being DISTRIBUTED over most of the sub-structure or as acting at a POINT of the sub-

- structure?
 ** DISTRIBUTED
 28) Which surface of the sub-structure does LOAD-COMPONENT-2 act NORMAL to? (If more than one surface, you should consider the loading as two or more component loadings)
 ** WIDTH-LENGTH
 29) Enter the magnitude of the distributed load (in psi):
 ** 3
 30) Are there any other load components associated with LOADING-2?
 ** NO
 31) Are there any other loading conditions associated with the outer wing (SUB-STRUCTURE-1)?
 ** NO
 32) Are there any other sub-structures of the 747 wing relevant to this analysis?
 ** YES

-----SUB-STRUCTURE-2-----

- 33) What is the name of SUB-STRUCTURE-2?
 ** INNER WING
 34) What is the material composing most of the inner wing (SUB-STRUCTURE-2)?
 ** HIGH-STRENGTH-ALUMINIUM
 35) Enter the average longest dimension of the inner wing (SUB-STRUCTURE-2) in inches (or <number> CMS):
 ** 520
 36) Enter the weight of the inner wing (SUB-STRUCTURE-2) in pounds (or <number> KGS):
 ** 32000
 37) Is the inner wing (SUB-STRUCTURE-2) thin-walled or solid?
 ** THIN-WALLED
 38) What is the configuration of support for the inner wing (SUB-STRUCTURE-2)?
 ** ONE-SIDE
 39) Is the inner wing (SUB-STRUCTURE-2) to be modelled as a 1, 2, or 3 dimensional system?
 ** 2
 40) Would you describe the construction of the inner wing (SUB-STRUCTURE-2) to be truss and/or frame elements (NETWORK), sheets and/or blocks of material (CONTINUUM), or a combination of both?
 ** CONTINUUM
 41) Is the overall geometry of the inner wing (SUB-STRUCTURE-2) curved or planar?
 ** CURVED
 The first loading applied to the inner wing (SUB-STRUCTURE-2) will be called:

-----LOADING-3-----

- 42) What is the name of LOADING-3?
 ** LANDING
 43) Enter the number of loading cycles to be applied:
 ** 20000
 The first load component associated with LOADING-3 will be called:

-----LOAD-COMPONENT-3-----

- 44) Would you describe LOAD-COMPONENT-3 as being DISTRIBUTED over most of the sub-structure or as acting at a POINT of the sub-

```

      structure?
** DISTRIBUTED
45) Which surface of the sub-structure does LOAD-COMPONENT-3 act
    NORMAL to? (If more than one surface, you should consider the
    loading as two or more component loadings)
** WIDTH-LENGTH
46) Enter the average wall thickness of the inner wing (SUB-
    STRUCTURE-2) in inches (or <number> CMS):
** .35
47) Enter the average depth of the inner wing (SUB-STRUCTURE-2)
    in inches (or <number> CMS):
** 52.5
48) Enter the magnitude of the distributed load (in psi):
** 3
49) Are there any other load components associated with LOADING-3?
** YES

-----LOAD-COMPONENT-4-----
50) Would you describe LOAD-COMPONENT-4 as being DISTRIBUTED over
    most of the sub-structure or as acting at a POINT of the sub-
    structure?
** POINT
51) Which surface of the sub-structure does LOAD-COMPONENT-4 act
    NORMAL to? (If more than one surface, you should consider the
    loading as two or more component loadings)
** WIDTH-LENGTH
52) Describe where on the sub-structure LOAD-COMPONENT-4 is
    applied:
** NEAR-SUPPORT
53) Enter the magnitude of the point load (in pounds):
** -17600
54) Are there any other load components associated with LOADING-3?
** YES

-----LOAD-COMPONENT-5-----
55) Would you describe LOAD-COMPONENT-5 as being DISTRIBUTED over
    most of the sub-structure or as acting at a POINT of the sub-
    structure?
** POINT
56) Which surface of the sub-structure does LOAD-COMPONENT-5 act
    NORMAL to? (If more than one surface, you should consider the
    loading as two or more component loadings)
** WIDTH-LENGTH
57) Describe where on the sub-structure LOAD-COMPONENT-5 is
    applied:
** NEAR-FREE-EDGE
58) Enter the magnitude of the point load (in pounds):
** 918000
59) Are there any other load components associated with LOADING-3?
** NO
60) Are there any other loading conditions associated with the inner
    wing (SUB-STRUCTURE-2)?
** NO

```

(NOTE: The flight loading on the inner wing was skipped in order to shorten an already quite lengthy example.)

61) Are there any other sub-structures of the 747 wing relevant to this analysis?

** YES

-----SUB-STRUCTURE-3-----

62) What is the name of SUB-STRUCTURE-3?

** TOTAL WING

63) What is the material composing most of the total wing (SUB-STRUCTURE-3)?

** HIGH-STRENGTH-ALUMINIUM

64) Enter the average longest dimension of the total wing (SUB-STRUCTURE-3) in inches (or <number> CMS):

** 1420

65) Enter the weight of the total wing (SUB-STRUCTURE-3) in pounds (or <number> KGS):

** 46000

66) Is the total wing (SUB-STRUCTURE-3) thin-walled or solid?

** THIN-WALLED

67) What is the configuration of support for the total wing (SUB-STRUCTURE-3)?

** ONE-SIDE

68) Is the total wing (SUB-STRUCTURE-3) to be modelled as a 1, 2, or 3 dimensional system?

** 2

69) Would you describe the construction of the total wing (SUB-STRUCTURE-3) to be truss and/or frame elements (NETWORK), sheets and/or blocks of material (CONTINUUM), or a combination of both?

** CONTINUUM

70) Is the overall geometry of the total wing (SUB-STRUCTURE-3) curved or planar?

** CURVED

The first loading applied to the total wing (SUB-STRUCTURE-3) will be called:

-----LOADING-4-----

71) What is the name of LOADING-4?

** FLIGHT

72) Enter the number of loading cycles to be applied:

** 20000

The first load component associated with LOADING-4 will be called:

-----LOAD-COMPONENT-6-----

73) Would you describe LOAD-COMPONENT-6 as being DISTRIBUTED over most of the sub-structure or as acting at a POINT of the sub-structure?

** DISTRIBUTED

74) Which surface of the sub-structure does LOAD-COMPONENT-6 act NORMAL to? (If more than one surface, you should consider the loading as two or more component loadings)

** WIDTH-LENGTH

75) Enter the average wall thickness of the total wing (SUB-STRUCTURE-3) in inches (or <number> CMS):

** .31

76) Enter the average depth of the total wing (SUB-STRUCTURE-3) in inches (or <number> CMS):

** 41

77) Enter the magnitude of the distributed load (in psi):

- ** 1
78) Are there any other load components associated with LOADING-4?
** NO
- 79) Are there any other loading conditions associated with the total wing (SUB-STRUCTURE-3)?
** YES
- LOADING-5-----
80) What is the name of LOADING-5?
** LANDING
- 81) Enter the number of loading cycles to be applied:
** 20000
The first load component associated with LOADING-5 will be called:
- LOAD-COMPONENT-7-----
82) Would you describe LOAD-COMPONENT-7 as being DISTRIBUTED over most of the sub-structure or as acting at a POINT of the sub-structure?
** DISTRIBUTED
- 83) Which surface of the sub-structure does LOAD-COMPONENT-7 act NORMAL to? (If more than one surface, you should consider the loading as two or more component loadings)
** WIDTH-LENGTH
- 84) Enter the magnitude of the distributed load (in psi):
** 3
- 85) Are there any other load components associated with LOADING-5?
** YES
- LOAD-COMPONENT-8-----
86) Would you describe LOAD-COMPONENT-8 as being DISTRIBUTED over most of the sub-structure or as acting at a POINT of the sub-structure?
** POINT
- 87) Which surface of the sub-structure does LOAD-COMPONENT-8 act NORMAL to? (If more than one surface, you should consider the loading as two or more component loadings)
** WIDTH-LENGTH
- 88) Describe where on the sub-structure LOAD-COMPONENT-8 is applied:
** NEAR-SUPPORT
- 89) Enter the magnitude of the point load (in pounds):
** -17600
- 90) Are there any other load components associated with LOADING-5?
** NO
- 91) Are there any other loading conditions associated with the total wing (SUB-STRUCTURE-3)?
** NO
- 92) Are there any other sub-structures of the 747 wing relevant to this analysis?
** NO
- 93) Do the supports of the 747 wing involve Coulomb friction, nonlinear springs, and/or gapping?
** NO

The following analysis classes are relevant to the analysis of your

structure:

- 1) general-inelastic
- 2) general-large-displacement
- 3) general-nonlinear

The following are specific analysis recommendations you should follow when performing the structure analysis:

Use large displacement formulation for stress and strain.

Consider whether forces retain orientation to structure or a fixed direction in space.

Solution will be based on a modified Newton-Raphson approach.

Activate incremental stress - incremental strain analysis.

Model nonlinear stress-strain relation of the material.

Logic to scan peak stress at each step and evaluate fatigue integrity should be used.

Logic to scan stresses, smooth, and compare with allowable stresses (with appropriate safety factors) should be used.

Logic to scan deflections, calculate relative values, and compare with code limits, should be called upon.

Flexibility evaluations should be made at each load step for user selected criterion loadings.

Cumulative strain damage should be calculated.

Analysis should include two or more load cycles (if cyclic) with extrapolation for strain accumulation.

Shakedown extrapolation logic should be used.

A single cycle of loading is sufficient for fatigue estimates.

(NOTE: The following is a post-analysis question-answering session between the user and SACON.)

Please ask questions now. When you are finished and want to begin a new consultation or sign off the terminal, enter the word STOP.

Type HELP for the list of question options.

** WHAT ARE THE STRESS PHENOMENA OF THE 747 WING

The stress behavior phenomena in the 747 wing are fatigue (1.0) stress-exceedence (1.0)

** WHAT ARE THE DEFLECTION PHENOMENA OF THE TOTAL WING
 The deflection phenomena in the 747 wing are flexibility-changes (1.0)
 excessive-deflection (1.0) incremental-strain-failure (1.0)

** HOW DID YOU CONCLUDE THE ANALYSIS CLASS OF STRUCTURE-1

The following rules concluded about:
 the analysis class of the 747 wing

Rule	cumulative certainty value & cumulative certainty	last question asked before conclusion was made
RULE035	GENERAL-LARGE-DISPLACEMENT (1.0)	93
RULE036	GENERAL-INELASTIC (1.0)	93
RULE037	GENERAL-NONLINEAR (1.0)	93

The parameters used in these rules were:
 the types of nonlinearity in the structure
 the stress behavior phenomena in the structure
 the deflection phenomena in the structure

(NOTE: The user may ask to see the text of any rule, as shown here.)

** PR 35

RULE035

 [This rule applies to any structure, and is tried in order to find out about
 the analysis class of the structure]

If: 1) Geometric is one of the types of nonlinearity in the structure, and
 2) There are some stress behavior phenomena in the structure, and
 3) There are some deflection phenomena in the structure

Then: It is definite (1.0) that general-large-displacement is one of the
 analysis class of the structure

** WHAT ARE THE TYPES OF NONLINEARITY OF STRUCTURE-1
 The types of nonlinearity in the 747 wing are geometric (1.0) material (1.0)

** WHAT IS THE STRESS MAGNITUDE OF LOAD-COMPONENT-1
 The stress magnitude of LOAD-COMPONENT-1 (in psi) is 107712.8

** WHAT IS THE DEFLECTION MAGNITUDE OF LOAD-COMPONENT-1
 The deflection magnitude of LOAD-COMPONENT-1 in inches is .0687528 inches

** HOW DID YOU CONCLUDE THE STRESS MAGNITUDE OF LOAD-COMPONENT-1

RULE142 was used to conclude that the stress magnitude of LOAD-COMPONENT-1

(in psi) is 107712.8. The last question asked before the conclusion was made was 22.

** PR 142

RULE142

 [This rule applies to any loading component, and is tried in order to find out about the stress magnitude of the load component (in psi), or the deflection magnitude of the load component in inches]

- If: 1) The surface to which the load component acts normal is width-length, and
 2) The distribution of the load component is distributed, and
 3) The configuration of support for the sub-structure is one-side, and
 4) The shape of the sub-structure is one of: the surface shapes, and
 5) The moment of inertia of the sub-structure is known, and
 6) The magnitude of the load component (in psi) is known, and
 7) The length of the sub-structure is known, and
 8) The depth of the sub-structure is known, and
 9) Young's modulus of the material is known

- Then: 1) It is definite (1.0) that the stress magnitude of the load component (in psi) is $\text{depth} * \text{dist-mag} * \text{length}^{\uparrow 2} / 4 * \text{einertia}$, and
 2) It is definite (1.0) that the deflection magnitude of the load component in inches is $\text{dist-mag} * \text{length}^{\uparrow 3} / 24 * \text{youngs-modulus} * \text{einertia}$

** WHAT IS THE STRESS BOUND OF LOADING-1

The maximum stress bound at a point, due to all components of LOADING-1 (in psi) is 107712.8 psi

** STOP

Do you wish advice on another structure?

** NO

4.2 Analysis of a Concrete Building

Figures 4.3 and 4.4 provide details of a College Union Building. Figure 4.3 is a schematic of the floors and columns and defines design loadings. Figure 4.4 shows some of the construction details. The building is formed of high-strength (4,000 psi) reinforced concrete.

Figure 4.5 summarizes data needed in the consultation. The building is represented by two substructures: a representative section of the floor and a model of the columns for loading in the north-south direction.

Consistent with preliminary design methods, the model described to the consultant assumes that the function of the reinforcing steel is to make the concrete effective for tensile stress. Thus, the model for consultation does not include reinforcement details.

The dialogue of the consultation is reproduced below.

Substructure 1—Floor Section

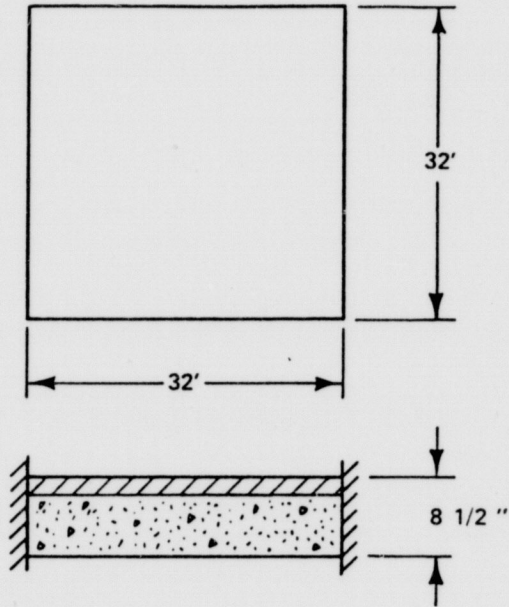

Weight = 108,800
 Dead Load = 106.25 psf
 Live load = 80.00
186.25 psf = 1.2934 psi

NOTES

1. Depth of concrete fill and slab
2. Weight of conc = $32 \times 32 \times \frac{8.5}{12} \times 150 = 108,800$
3. Dead load = $\frac{t}{12} \times 150 = \frac{8.5}{12} \times 150 = 106.25$ psf

Substructure 2—N.S. Frame

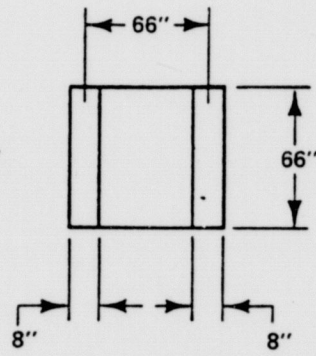
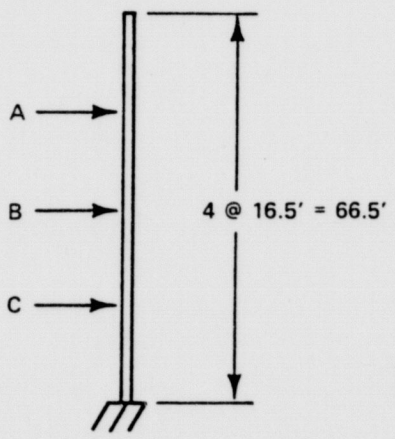

800,000 cycles of wind
 Weight = 1,160,000

POINT	WIND P*	QUAKE P,*
A	81,005	2,762,500
B	81,005	1,961,500
C	81,005	1,166,500

*P=point load

1. Depth of section and thickness of walls to match real concrete

Fig. 4.3

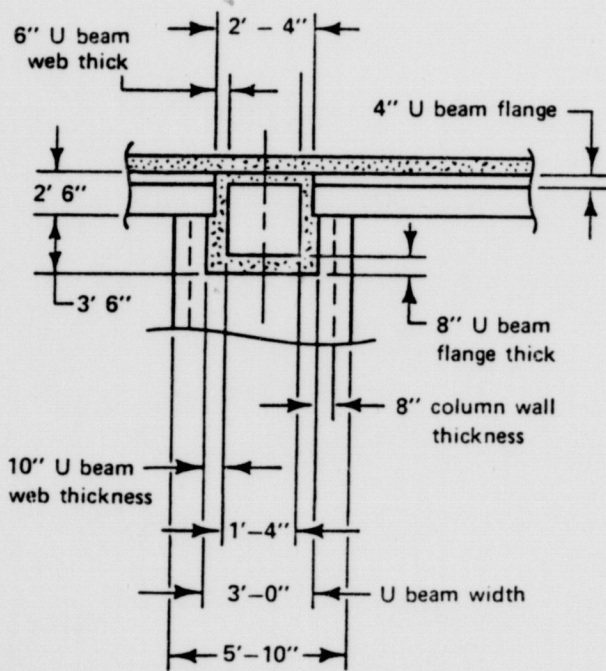
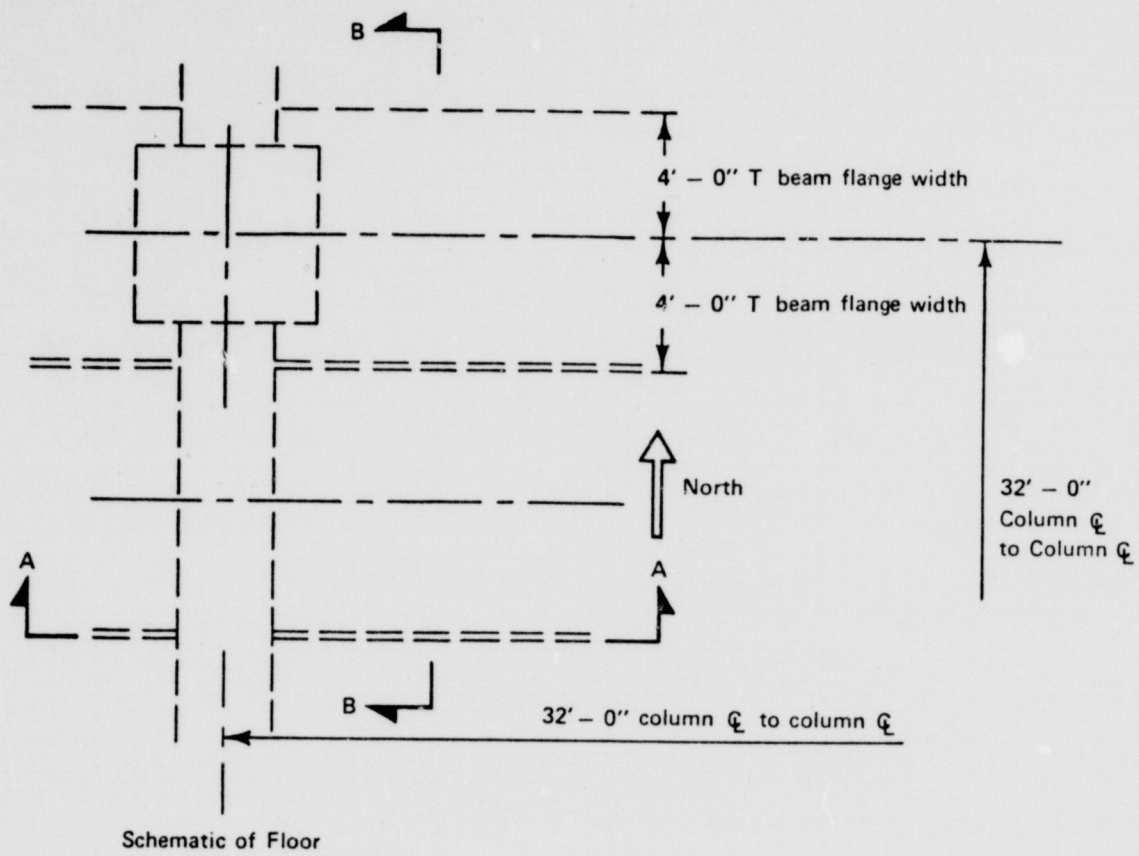

A-A Schematic of U Beam

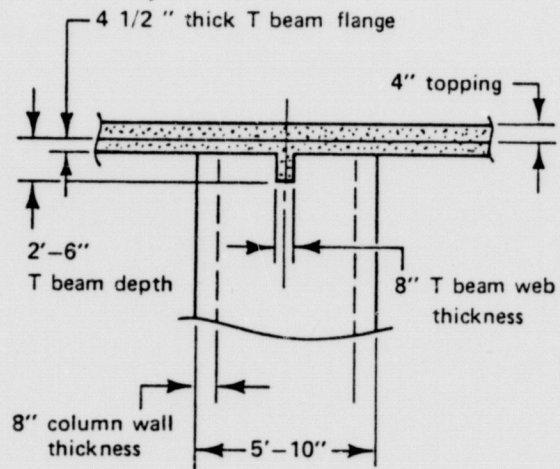

B-B Schematic of Column and Decking

Fig. 4.4

COLLEGE UNION BUILDING

Analysis Model

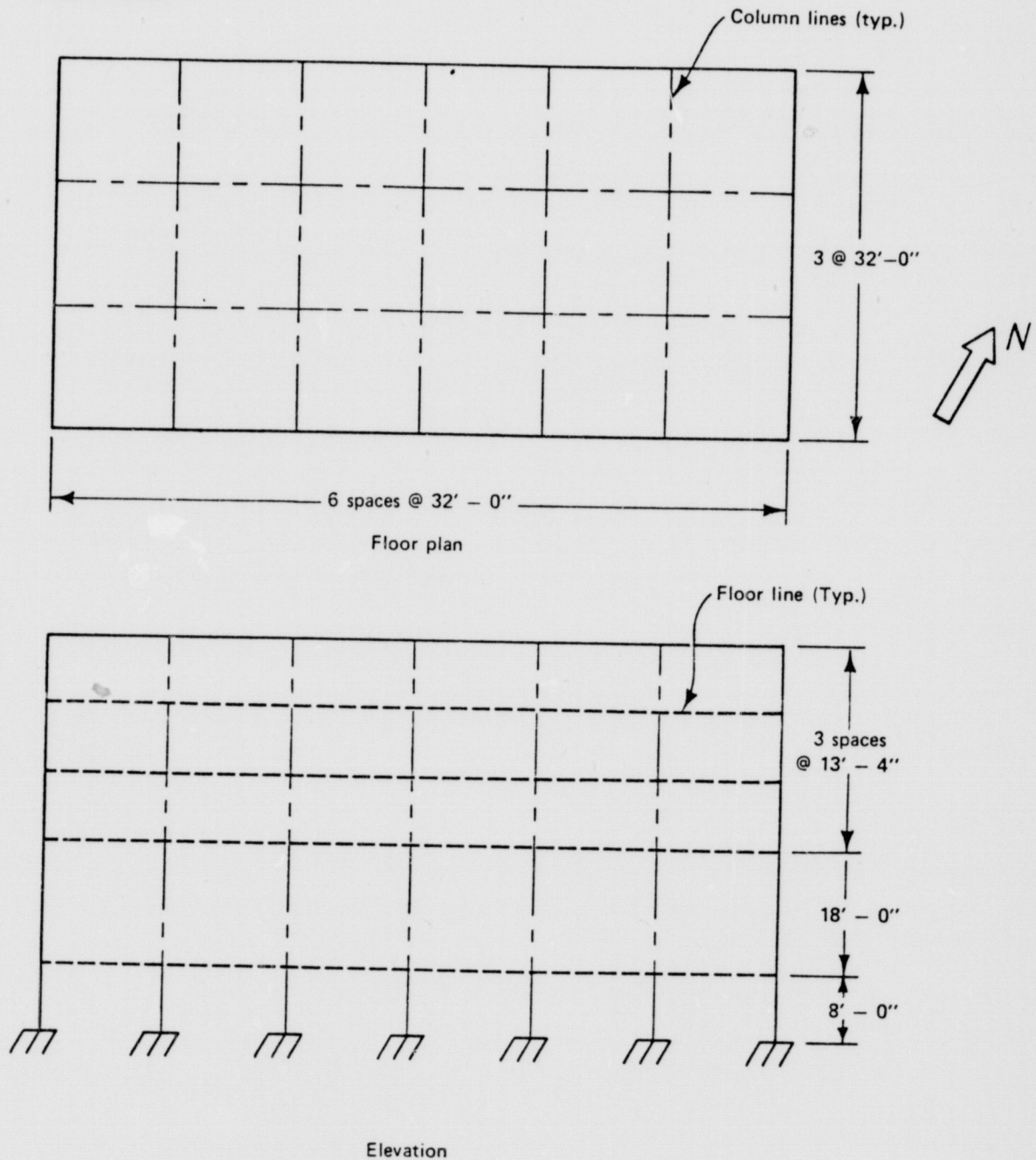

LOADS

- 80 psf floor live loading
- Dead load of concrete structure
- .3 g N-S, .25 g E-W earthquake acceleration
- 100 MPH wind loading N-S = 25.57 psf
- 80 MPH wind loading E-W = 16.36 psf
- Critical load = wind or earthquake + .5 wind
- 1000 cycles of loading due to earthquake

Fig. 4.5

September 9, 1978 10:40AM in <SACON>SACON.SAV;80908 by SACON

Loading <SACON>STRUCTURE.24;1...

THIS IS THE CONSULTATION FOR THE COLLEGE UNION BUILDING. THE PURPOSE OF THIS EXAMPLE IS TO ILLUSTRATE A TYPICAL CONSULTATION. THUS, IT DEALS WITH MULTIPLE SUBSTRUCTURES (2), LOADINGS (2), AND LOADING COMPONENTS. IT ASSUMES THAT THE ANALYSIS OBJECTIVE IS TO EVALUATE RESPONSE INTEGRITY AND STABILITY UNDER STATIC LOADINGS CAUSED BY GRAVITY, WIND, AND EARTHQUAKE.

9-Sep-78 10:40:43
[consultation of 7-Jul-78 4:45PM]

-----STRUCTURE-24-----

- 1) What is the name of STRUCTURE-24?
** COLLEGE UNION BUILDING
- 2) Assuming that your characterization of the college union building in terms of its geometry, material characteristics, and boundary conditions are accurate, how much error (in percent) is tolerable for the analysis?
** 10
- 3) Do you want to examine the responses of the college union building, to evaluate its instability, or both?
** BOTH
- 4) Does the college union building have any time dependent terms in its equations of equilibrium?
** NO
- 5) Is heating or cooling of interest in determining structure responses?
** NO
- 6) Have you decomposed the college union building into a number of potential sub-structures which are relevant to this analysis?
** YES

-----SUB-STRUCTURE-1-----

- 7) What is the name of SUB-STRUCTURE-1?
** FLOOR SECTION
- 8) What is the material composing most of the floor section (SUB-STRUCTURE-1)?
** ?

(NOTE: The user may respond to a question with a question mark. The system responds with a list of expected responses.)

What is the material composing the floor section (SUB-STRUCTURE-1)?
Expected responses are: HIGH-STRENGTH-ALUMINIUM UPGRADED-ALUMINIUM
STRUCTURAL-ALUMINIUM HIGH-STRENGTH-STEEL UPGRADED-STEEL
STRUCTURAL-STEEL CONCRETE HIGH-STRENGTH-CONCRETE
Enter HELP for list of user options.
** WHY

(NOTE: The user may respond to any prompting with "WHY", thereby calling in the explanation facility of SACON. SACON responds by telling the user what its current sub-goal is--in this case stress behavior--and the context in which its attention is focused--sub-structure 1 here.)

[i.e. WHY is it important to determine the material composing SUB-STRUCTURE-1?]

- [1.0] The material composing a sub-structure is one of the 9 standard parameters that identify a sub-structure.
This may be useful later in the consultation. For example, it is very important in determining the stress behavior phenomena in SUB-STRUCTURE-1 and is significant in determining the stress criterion of SUB-STRUCTURE-1.

[back to question 8...]

** CONCRETE

9) Enter the average longest dimension of the floor section (SUB-STRUCTURE-1) in inches (or <number> CMS):

** 32 FT

10) Enter the weight of the floor section (SUB-STRUCTURE-1) in pounds (or <number> KGS):

** 108800

11) Is the floor section (SUB-STRUCTURE-1) thin-walled or solid?

** SOLID

12) What is the configuration of support for the floor section (SUB-STRUCTURE-1)?

** FOUR-SIDES

13) Is the floor section (SUB-STRUCTURE-1) to be modelled as a 1, 2, or 3 dimensional system?

** 2

14) Would you describe the construction of the floor section (SUB-STRUCTURE-1) to be truss and/or frame elements (NETWORK), sheets and/or blocks of material (CONTINUUM), or a combination of both?

** CONTINUUM

15) Is the overall geometry of the floor section (SUB-STRUCTURE-1) curved or planar?

** PLANAR

The first loading applied to the floor section (SUB-STRUCTURE-1) will be called:

-----LOADING-1-----

16) What is the name of LOADING-1?

** TOTAL LOADING

17) Enter the number of loading cycles to be applied:

** 1000

The first load component associated with LOADING-1 will be called:

-----LOAD-COMPONENT-1-----

18) Would you describe LOAD-COMPONENT-1 as being DISTRIBUTED over most of the sub-structure or as acting at a POINT of the sub-structure?

** DISTRIBUTED

19) Which surface of the sub-structure does LOAD-COMPONENT-1 act NORMAL to? (If more than one surface, you should consider the loading as two or more component loadings)

** WIDTH-LENGTH

20) Enter the magnitude of the distributed load (in psi):

** 1.2934

21) Enter the average depth of the floor section (SUB-STRUCTURE-1) in inches (or <number> CMS):

** 8.5

- 22) Are there any other load components associated with LOADING-1?
 ** NO
- 23) Are there any other loading conditions associated with the floor section (SUB-STRUCTURE-1)?
 ** NO
- 24) Are there any other sub-structures of the college union building relevant to this analysis?
 ** YES

-----SUB-STRUCTURE-2-----

- 25) What is the name of SUB-STRUCTURE-2?
 ** NORTH-SOUTH COLUMNS
- 26) What is the material composing most of the north-south columns (SUB-STRUCTURE-2)?
 ** HIGH-STRENGTH-CONCRETE
- 27) Enter the average longest dimension of the north-south columns (SUB-STRUCTURE-2) in inches (or <number> CMS):
 ** 66.5 FT
- 28) Enter the weight of the north-south columns (SUB-STRUCTURE-2) in pounds (or <number> KGS):
 ** 1160000
- 29) Is the north-south columns (SUB-STRUCTURE-2) thin-walled or solid?
 ** THIN-WALLED
- 30) What is the configuration of support for the north-south columns (SUB-STRUCTURE-2)?
 ** ONE-SIDE
- 31) Is the north-south columns (SUB-STRUCTURE-2) to be modelled as a 1, 2, or 3 dimensional system?
 ** 1
- 32) Would you describe the construction of the north-south columns (SUB-STRUCTURE-2) to be truss and/or frame elements (NETWORK), sheets and/or blocks of material (CONTINUUM), or a combination of both?
 ** NETWORK
 The first loading applied to the north-south columns (SUB-STRUCTURE-2) will be called:

-----LOADING-2-----

- 33) What is the name of LOADING-2?
 ** WIND
- 34) Enter the number of loading cycles to be applied:
 ** 800000
 The first load component associated with LOADING-2 will be called:

-----LOAD-COMPONENT-2-----

- 35) Would you describe LOAD-COMPONENT-2 as being DISTRIBUTED over most of the sub-structure or as acting at a POINT of the sub-structure?
 ** POINT
- 36) Which surface of the sub-structure does LOAD-COMPONENT-2 act NORMAL to? (If more than one surface, you should consider the loading as two or more component loadings)
 ** WIDTH-LENGTH
- 37) Describe where on the sub-structure LOAD-COMPONENT-2 is applied:
 ** NEAR-FREE-EDGE

38) Enter the magnitude of the point load (in pounds):
** 81005

39) Enter the average depth of the north-south columns (SUB-STRUCTURE-2) in inches (or <number> CMS):
** 66

40) Enter the average wall thickness of the north-south columns (SUB-STRUCTURE-2) in inches (or <number> CMS):
** 8

41) Are there any other load components associated with LOADING-2?
** YES

-----LOAD-COMPONENT-3-----

42) Would you describe LOAD-COMPONENT-3 as being DISTRIBUTED over most of the sub-structure or as acting at a POINT of the sub-structure?
** POINT

43) Which surface of the sub-structure does LOAD-COMPONENT-3 act NORMAL to? (If more than one surface, you should consider the loading as two or more component loadings)
** WIDTH-LENGTH

44) Describe where on the sub-structure LOAD-COMPONENT-3 is applied:
** NEAR-CENTROID

45) Enter the magnitude of the point load (in pounds):
** 81005

46) Are there any other load components associated with LOADING-2?
** YES

-----LOAD-COMPONENT-4-----

47) Would you describe LOAD-COMPONENT-4 as being DISTRIBUTED over most of the sub-structure or as acting at a POINT of the sub-structure?
** POINT

48) Which surface of the sub-structure does LOAD-COMPONENT-4 act NORMAL to? (If more than one surface, you should consider the loading as two or more component loadings)
** WIDTH-LENGTH

49) Describe where on the sub-structure LOAD-COMPONENT-4 is applied:
** NEAR-SUPPORT

50) Enter the magnitude of the point load (in pounds):
** 81005

51) Are there any other load components associated with LOADING-2?
** NO

52) Are there any other loading conditions associated with the north-south columns (SUB-STRUCTURE-2)?
** YES

-----LOADING-3-----

53) What is the name of LOADING-3?
** WIND+QUAKE

54) Enter the number of loading cycles to be applied:
** 1

The first load component associated with LOADING-3 will be called:

-----LOAD-COMPONENT-5-----

- 55) Would you describe LOAD-COMPONENT-5 as being DISTRIBUTED over most of the sub-structure or as acting at a POINT of the sub-structure?
** POINT
- 56) Which surface of the sub-structure does LOAD-COMPONENT-5 act NORMAL to? (If more than one surface, you should consider the loading as two or more component loadings)
** WIDTH-LENGTH
- 57) Describe where on the sub-structure LOAD-COMPONENT-5 is applied:
** NEAR-FREE-EDGE
- 58) Enter the magnitude of the point load (in pounds):
** 2762500
- 59) Are there any other load components associated with LOADING-3?
** YES
- LOAD-COMPONENT-6-----
- 60) Would you describe LOAD-COMPONENT-6 as being DISTRIBUTED over most of the sub-structure or as acting at a POINT of the sub-structure?
** POINT
- 61) Which surface of the sub-structure does LOAD-COMPONENT-6 act NORMAL to? (If more than one surface, you should consider the loading as two or more component loadings)
** WIDTH-LENGTH
- 62) Describe where on the sub-structure LOAD-COMPONENT-6 is applied:
** NEAR-CENTROID
- 63) Enter the magnitude of the point load (in pounds):
** 1961500
- 64) Are there any other load components associated with LOADING-3?
** YES
- LOAD-COMPONENT-7-----
- 65) Would you describe LOAD-COMPONENT-7 as being DISTRIBUTED over most of the sub-structure or as acting at a POINT of the sub-structure?
** POINT
- 66) Which surface of the sub-structure does LOAD-COMPONENT-7 act NORMAL to? (If more than one surface, you should consider the loading as two or more component loadings)
** WIDTH-LENGTH
- 67) Describe where on the sub-structure LOAD-COMPONENT-7 is applied:
** NEAR-SUPPORT
- 68) Enter the magnitude of the point load (in pounds):
** 1166500
- 69) Are there any other load components associated with LOADING-3?
** NO
- 70) Are there any other loading conditions associated with the north-south columns (SUB-STRUCTURE-2)?
** NO
- 71) Are there any other sub-structures of the college union building relevant to this analysis?
** NO
- 72) Do the supports of the college union building involve Coulomb friction, nonlinear springs, and/or gapping?

** NO

The following analysis classes are relevant to the analysis of your structure:

1) general-inelastic

The following are specific analysis recommendations you should follow when performing the structure analysis:

Activate incremental stress - incremental strain analysis.

Model nonlinear stress-strain relation of the material.

Solution will be based on a mix of gradient and Newton methods.

Logic to scan stresses, smooth, and compare with allowable stresses (with appropriate safety factors) should be used.

Kinematic collapse mode evaluation logic should be used when stiffness degenerates to zero.

Cumulative strain damage should be calculated.

Analysis should include two or more load cycles (if cyclic) with extrapolation for strain accumulation.

Shakedown extrapolation logic should be used.

4.3 Conclusions

These consultations illustrate the ability of the consultation system to:

- 1) treat a structure as a collection of substructures,
- 2) treat loadings by superimposing load components,
- 3) model aluminum or concrete plate or beam-like structures,
- 4) consider analysis objectives that include response prediction only, or both response and instability,
- 5) produce a citation of all conclusions reached,
- 6) respond to questions about the basis for a conclusion, and
- 7) define the values of consultation parameters developed.

5 Summary

5.1 What did we accomplish

We regard the work reported here as a further demonstration that recent AI research in knowledge-based systems has sufficient generality to serve in a variety of application domains.

Specific conclusions:

- 1) The automated structural analysis consultant is an appropriate task domain for a MYCIN-like rule-based interactive consultation system. Although several iterations of the knowledge base were made before it was honed to the satisfaction of the expert, the rule-based representation of the expert's knowledge of structural engineering and the MARC program proved adequate (if not entirely "natural").
- 2) A relatively sophisticated and helpful automated consultant can be designed and implemented with a modest expenditure of effort, by exploiting the general representation and interactive facilities of the EMYCIN system. To bring the SACON program to its present level of performance, we estimate that two man-months of the expert's time were required to explicate his task as a consultant and formulate the knowledge base, and about the same amount of time implementing and testing the rules ¹.
- 3) The performance of the SACON program matches that of a human consultant for the limited domain of structural analysis problems that was initially selected. The choice of an analysis strategy is only one of the critical decisions that an engineer must make before attempting to use the MARC program; there are many other decisions he must also make, e.g. choosing the appropriate geometry, for which the present version of SACON provides no assistance. We have no reason to doubt, however, that the level of performance and range of applicability of the present consultant can be significantly raised by expanding the knowledge base.

5.2 Contributions to Artificial Intelligence

5.2.1 EMYCIN as a Representation Vehicle

A primary goal of this research was to determine if current "knowledge engineering" techniques could be usefully applied in the development of a computer-based consultant in structural analysis. Specifically, our research was a test of the generality of the rule-based formalism of the EMYCIN system. As such, we neither explored the use of other available consultation systems (e.g. PROSPECTOR, RITA) nor examined the pros and cons of using the different representation schemes they provide. Rather, our decision to utilize the

¹ This estimate does not include the necessary time devoted to meetings, problem formulation, demonstrations and report writing.

production-rule formalism of EMYCIN allowed us to focus our attention on the structural analysis task itself. At no time did we find this choice of knowledge representation to be a hindrance to either the explication of the knowledge from the expert or its eventual implementation in the SACON program. In fact the relative simplicity of using and explaining the rule-based formalism actually facilitated the rapid development of the knowledge base during the early stages of the consultant's design.

Moreover, the backward-chaining control structure of EMYCIN did not prove to be a barrier for eliciting the expert's knowledge. Indeed, the existence of alternative control structures was never discussed with the expert; he was 'required' to explicate his knowledge in a backward-chained control environment. The control structure, like the rule-based formalism, seemed to impose a salutary discipline on the expert as he formulated the knowledge base. Similar effects on the knowledge acquisition process have been observed by other researchers (Wlnograd, personal communication) even when a choice of control structures is available; typically a single control method (agenda, backward chaining, etc.) is selected and, once chosen, this control structure provides a framework for the explication of knowledge.

One feature of EMYCIN that was not used in this task was the confidence factor mechanism, i.e. the ability to draw inferences with uncertain knowledge. The consultation strategy, and the associated mathematical model, were designed to determine extreme loading conditions, from which SACON concludes the appropriate analysis class. Consequently, by using a "conservative" model the rules, though inexact in themselves, are sufficiently accurate for predicting bounds that they can be stated with certainty.

5.2.2 Validation of Domain-Independence

The development of SACON represents a major test of the domain-independence of the EMYCIN system. Previous applications using EMYCIN have been primarily medical with the consultations focusing on the diagnosis and prescription of therapy for a patient. Structural analysis, with its emphasis on structures and loadings, allowed us to detect the small number of places where this medical bias had unduly influenced the system design, notably text strings used for prompting and giving advice.

Our expert found that his knowledge was easily cast into the rule-based formalism and that the existing predicate functions and context-tree mechanism provided sufficient expressive power to capture the task of recommending an analysis strategy. The existing interactive facilities for performing explanation, question-answering, and consultation were found to be well developed and directly usable by our application. As mentioned previously, none of these features required any significant reprogramming¹ and for the most part, worked without modification. Examples of these facilities in use during a consultation were demonstrated in Section 4.

¹ The project required the development of three new predicate functions and a minor modification of the consultation interaction abilities to handle multi-valued parameters more naturally. Multi-valued parameters had not been used heavily in the medical applications, and the extensions we provided are now included in the EMYCIN system.

5.2.3 Observations about the Knowledge Acquisition process

Our experience explicating the structural analysis rule base provided an opportunity to make some observations about the process of knowledge acquisition. Although these observations were made with respect to the development of SACON, other knowledge-based consultation systems have noted similar processes and interactions.

Our principal observation is that the knowledge acquisition process is composed of three major phases. These phases are characterized strongly by the types of interaction that occur between expert and knowledge engineer and by the types of knowledge that are being explicated and transferred between the participants during these interactions. At present only a small fraction of these interactions can be held directly with the knowledge-based system itself [Davis77] [Davis76], and research continues to expand the knowledge acquisition expertise of these systems.

The Beginning Phase:

The beginning phase of the knowledge explication process is characterized by the expert's ignorance of knowledge based systems and his unfamiliarity with the process of describing explicitly what exactly he knows and does. At the same time, the knowledge engineers are notably ignorant about the application domain and clumsily seek, by analogy, to characterize the possible consultation tasks that could be performed (i.e. "Well, in MYCIN we did this...").

During the first month or so, the knowledge engineers and the domain expert become familiar with each other's fields. The expert learns what tools are available for representing his knowledge, and the knowledge engineer learns the important concepts of the domain. During this time both parties agree on the goal of the consultation, and on the vehicle that will be used to accomplish it. A taxonomy of the potential consultation areas for the application domain and the types of advice that could be given is formulated. Typically a small fragment of the complete spectrum of consultation tasks is selected and developed during the following phases of the knowledge acquisition effort. For example, the MYCIN project began by limiting the domain of expertise to bacteremia (blood infections); SACON is currently restricted to analysis strategies for structures exhibiting nonlinear, non-thermal, time-independent material behaviors.

The Middle Phase:

After identifying the sub-domain that will be developed, effort concentrates on the identification of the major factors and reasoning chains used by the expert to characterize the object of the consultation (be it patient or airplane wing) and to recommend any advice. It is useful to distinguish two phases within the middle phase that we term Early Middle and Late Middle. Early Middle is characterized by the development of the domain vocabulary and a small number of reasoning chains (rules) that indicate how the concepts relate to one another. For MYCIN-like systems, the context tree and the basic parameter structure is developed during this period. The Late Middle phase is characterized by the detailing of reasoning chains and development of the major rule sets in the system. During the Middle phase enough knowledge is explicated to advise a large number of common cases.

The End Phase:

When the knowledge base is substantially complete, the system designers concentrate on debugging the existing rule base. This debugging process typically involves the addition of single rules to handle obscure cases and might involve the introduction of new parameters. However the major structure of the knowledge base remains intact (at least for this sub-domain) and interactions with the expert involve relatively small changes.

Any further development of new sub-domains by the expert will involve cycling between the Middle and End phases of activity. The characterization of the domain, produced in the Beginning phase, remains fixed, and provides a framework in which new sub-domains must be couched.

While developing the SACON system, we profited during the Middle phase by 'hand-simulating' any proposed rules and parameter additions. In particular, major advances in building the structural analysis knowledge base came when one of us would "play EMYCIN" with the expert. During these sessions the knowledge engineer would prompt the expert for tasks that needed to be performed. By simulating the back-chaining manner of EMYCIN we asked, as needed, for rules to infer the parameter values, 'fired' these rules, and thus defined a large amount of the parameter, object, and rule space used during the present consultations. This process of simulating the EMYCIN system also helped the expert learn how the program worked in detail; he was then able to develop more rules and parameters without our continued interaction.

5.3 Extensions to SACON

There are at least two ways to extend the current work. One is to raise the level of performance of the program by extending its knowledge base. For example, the rules should be expanded to include time-dependent and thermal loading conditions.

Another possible development, of more interest than the former, is to integrate SACON and MARC in a single, closed-loop system. That is, the recommendations of SACON could be submitted to an intermediate program which translated these recommendations into specific input data for MARC. Then, after the MARC program performed its analysis on the structure, the results could be fed back to SACON for comparison with its initial predictions of the structure's behavior, based on its simplified mathematical model (see Fig. 5.1). The engineer could then be informed that the results of the MARC run were or were not reasonable. In cases where the MARC results did not agree with SACON's expectations, an alternate analysis strategy could be recommended to the engineer. If the user were an expert analyst, he may intervene at this point to enter new or more accurate rules into the knowledge base.

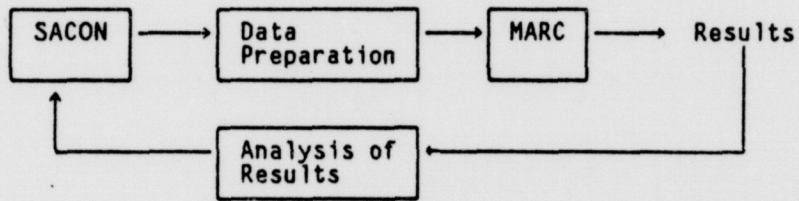

Fig. 5.1 Schematic of closed-loop structural analysis system